

INSTRUCTION MANUAL

SpiroExpand PicoControl Compact (EPCK)



Copyright ©

All rights reserved. No part of this user manual may be reproduced and/or published on the Internet, by means of printing, photocopying, microfilm or in any other way without the prior written permission of Spirotech bv.

TABLE OF CONTENTS

1.	PREFACE	5
	1.1. About the device	5
	1.2. About this document.....	5
	1.3. symbols	5
2.	SAFETY	6
3.	GENERAL.....	8
	3.1. Description of the device.....	8
	3.2. CE mark.....	9
	3.3. Type plate	9
4.	ASSEMBLY	10
	4.1. Setting up the device	10
	4.2. SpiroExpand PicoControl EPCF backfeed module	11
	4.3. Connection to the water supply system.....	12
	4.4. Use of cooling vessels.....	13
	4.5. Temperature sensor T2	14
	4.6. Electrical connection	15
5.	HYDRAULIC CONNECTION DIAGRAMS	16
	5.1. SpiroExpand PicoControl Compact EPCK with degassing function (standard scheme):	16
	5.2. SpiroExpand PicoControl compact EPCK without degassing function:.....	17
	5.3. SpiroExpand PicoControl compact EPCK with degassing function with cooling vessel:.....	18
6.	CIRCUIT DIAGRAMS	19
7.	COMMISSIONING	23
8.	MAINTENANCE	27
	8.1. Cleaning.....	27
	8.2. Maintenance	27
9.	SPARE PARTS LIST.....	28
	9.1. Expansion tank	28
	9.2. Piping	29
	9.3. Elektronik.....	30

10.	CERTIFICATES	31
11.	APPENDIX	32
	11.1. Sizing the expansion line	32

Disclaimer of Liability

This instruction manual has been prepared with the greatest care possible. However, we are constantly striving to improve our products and we reserve the right to make changes at any time and without prior notice. We do not guarantee the accuracy and completeness of this document. Any claims, in particular claims for damages and loss of profit or financial loss, are excluded.

1. PREFACE

1.1. About the device

These operating instructions cover the installation, commissioning and operation of SpiroExpand PicoControl Compact devices.





1.2. About this document

Read these operating instructions carefully before installation, commissioning and operation. Keep the instructions for future reference.

The illustrations in this document show a typical structure with relevant details and may differ from the model supplied depending on the type and equipment, but do not affect the comprehensibility of this document.

1.3. symbols

The following symbols are used in these operating instructions:

SYMBOLS		
	DANGER	This symbol warns of an imminent and extremely dangerous situation in which failure to observe the hazard warning will result in death or serious irreversible injury.
	WARNING	This symbol warns of an extremely dangerous situation in which failure to observe the hazard warning may result in death or serious irreversible injury.
	CAUTION	This symbol warns of a dangerous situation in which failure to observe the hazard warning may result in minor, reversible injuries.
	NOTE	This symbol warns of situations in which failure to observe the instructions can lead to material damage.
	INFORMATION	This symbol provides the user with useful information on the system design.

2. SAFETY

This safety information warns the user of risks and shows how the risks can be avoided. Due to the design of the pressurisation unit, hardly any hazards are to be expected.

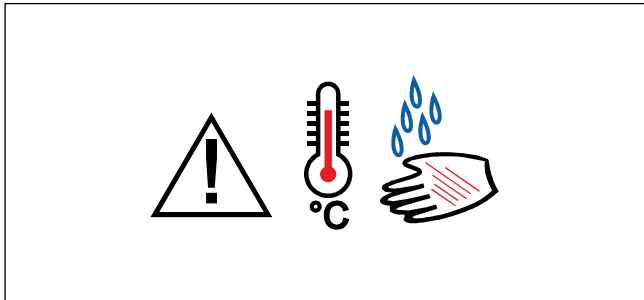

Figure 1: Danger notice



Figure 2: Danger notice

However, it should always be noted that hot system media (e.g. heating water) or even harmful media can leak out when handling these devices!

Since different devices each may have a special medium contained within, Spirotech cannot predict which medium the respective system will use. This also applies to harmful mixtures of media that may be used in the system.

It is the responsibility of the person setting up the system and, after proper handover, the responsibility of the operator of the system to take appropriate safety precautions if necessary and to affix warning notices to the device!

The following areas of application are expressly excluded:

- Use in potentially explosive atmospheres
- Use outdoors
- Use in rooms with risk of water jets
- Use in areas with heavily polluted ambient air

If it is the case that the system medium is a hazardous, harmful substance, the following hazardous situations may arise:

There is a 0.5 bar safety valve on the top flange of the tank, which can be triggered by the following causes and thus allow hot and harmful system media to escape:

- The expansion valve and the expansion tank have been sized incorrectly (too small) and the entire expansion volume cannot be accommodated in the tank.
- The content measurement may not work correctly due to defective pressure transmitters or a defective membrane, which can cause the container to overflow.
- The tank was filled to too high a level when cold (possibly by the "Fill once" function or uncontrolled if the EPCF backfeed module is not installed), whereby the expansion volume that occurs was not taken into account and can therefore no longer be fully absorbed in the tank.

In this case there is a risk of scalding!

- There is a plug at the bottom of the container, which is not expected to pose any danger during normal operation. If for any reason the membrane installed in the tank is defective, hot and harmful system medium can escape when this plug is opened.

In this case there is a risk of scalding!

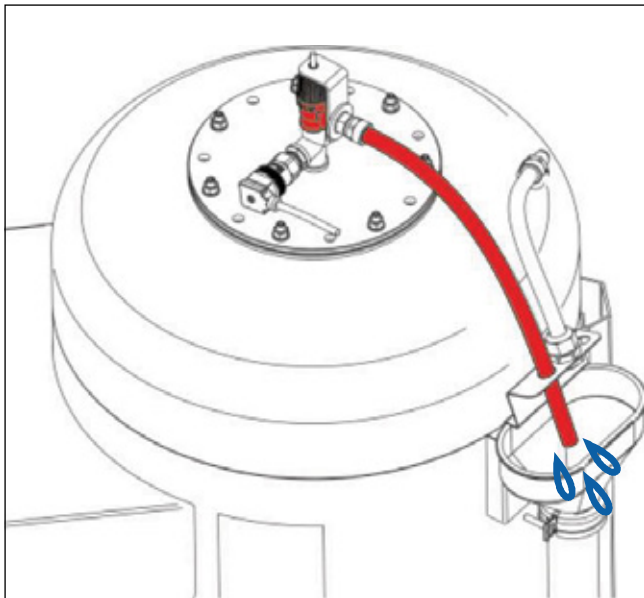

Figure 3: Safety valve of the container

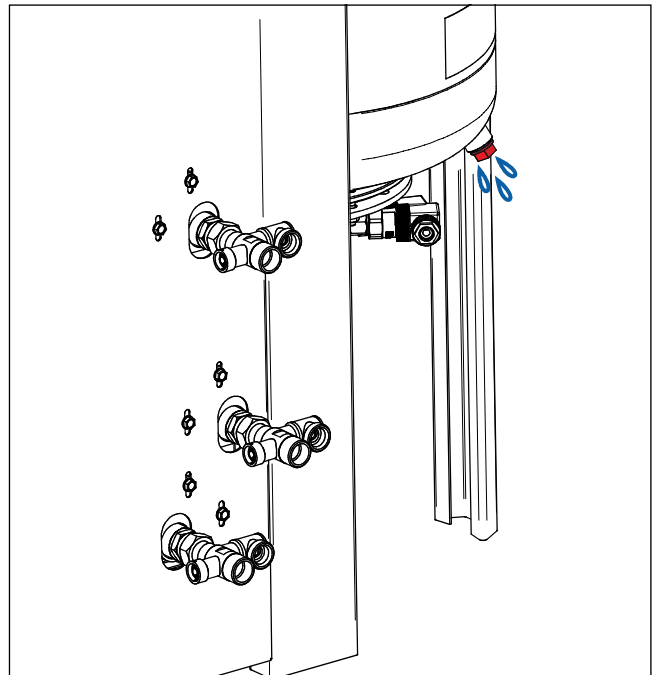

Figure 4: Emptying tap of the vessel

WARNING

- Installation, commissioning and servicing may only be carried out by trained specialist personnel.
- If the device is damaged, it must be taken out of operation and repaired by trained specialists.
- The device must be de-energised before carrying out any electrical work!
- No changes may be made to the product.
- Operation is only permitted with the housing closed.

NOTE

Illustrations in this document may differ from the model supplied depending on the type and equipment.

NOTE

Spirotech devices are subjected to a functional test at the factory before delivery and the device is filled with a frost-protected ready-mixed test water. Although the device is emptied as far as possible after the function test, small quantities of testing water (max. approx. 1.5 litres) may remain in the device, depending on the device type and design.

This test water is frost-protected down to -20°C and is produced on the basis of propylene glycol together with protective substances. Experience has shown that such small quantities of test water in the system do not cause any problems at the final destination when mixed with the system water there.

However, if there are concerns about the introduction of such a small amount of test water into the system at the destination, the pressurisation unit must also be flushed before connecting it to the system in the same way as is specified for the system itself (e.g. in ÖNORM H5195-1)

3. GENERAL

3.1. Description of the device

SpiroExpand PicoControl Compact Solo (EPCK-S) for loss-free absorption of the expansion volume and for pressure stabilisation in closed heating, air-conditioning and cooling systems. Manufactured in accordance with the EN 12828 construction guidelines.

Elegant, self-contained unit in self-supporting, sound-insulating design with attached, unpressurised expansion tank (max. 0.5 bar), designed as a painted steel tank (100% of the volume can be used, volume expansion through additional vessels is not prepared at the factory). High-quality, exchangeable tank membrane flanged on both sides for optimum separation of system medium and atmosphere. Vessel level measurement with two pressure transmitters on the tank flanges. Safety valve 0.5bar for container protection.

Control unit as compact hydraulics with a low-noise pressure maintenance pump (1x100%) in centrifugal pump design with high-quality mechanical shaft seal, a mechanically adjusted overflow valve (1x100% of the expansion volume flow) with continuous pressure proportional control. Precision system pressure measurement. Hydraulic connections for on-site integration on the right and designed with necessary shut-offs and disconnection option from the system. Temperature monitoring of the system medium entering the tank. Prepared connection point for easy assembly of the backfeed module for quantity-controlled, litre-precise backfeed, also available for retrofitting at any time. Water treatment can be combined with the backfeed module (softening, demineralisation) for standard-compliant backfeed water.

Electronic control unit in microprocessor design for controlling all processes, ergonomically arranged control panel with sophisticated operating concept in many national languages. Self-contained compact measuring and switching unit in closed switch cabinet design including connection cables. Three potential-free signalling contacts (fault, warning, backfeed running) are already included in the basic version.

Remote monitoring of the device is also possible using various multicontrol bus modules or multicontrol web module (also prepared for retrofitting).

Automatic, economical low-pressure degassing function based on the principle of depressurisation integrated as standard. Additional external temperature monitoring provided by optional temperature sensor at the point of integration into the system.

- max. safety temperature of the system: 110 degrees C (with cooling vessel)
- max. temperature at the connection point: 70 degrees C
- max. operating pressure (PN): 6 bar

3.2. CE mark

The device is CE labelled. This means that the device has been developed, built and tested in accordance with the applicable health and safety regulations. Provided that the operating instructions are followed, the device can be used and maintained safely.

3.3. Type plate

The rating plate of the device is located on the side of the device and is shown in the illustration below.

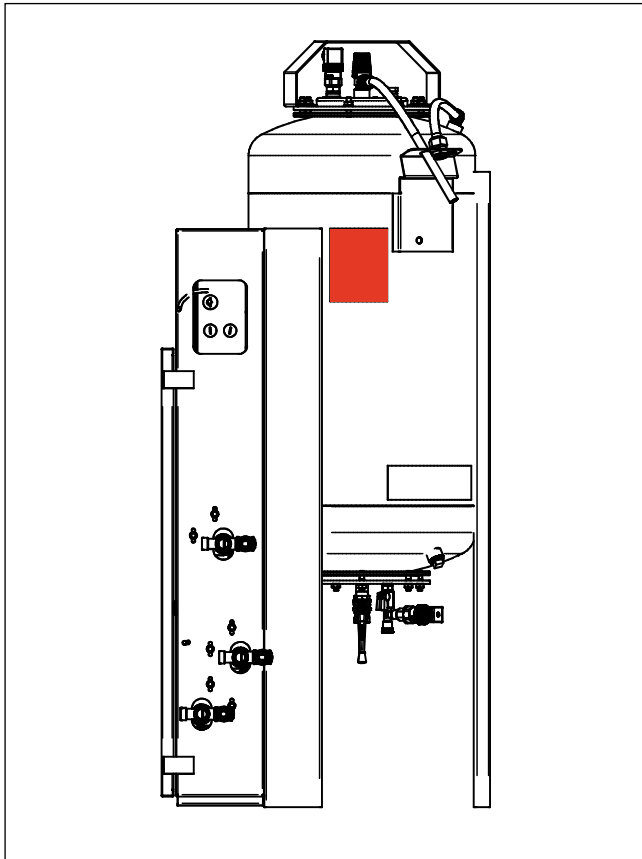

Figure 5: Type plate

4. ASSEMBLY

4.1. Setting up the device

The device must be set up on a level, solid floor. Any unevenness must be levelled out. Setting the device up outdoors is not permitted.

The connection of all hydraulic lines from the Spirotech device to the system must be as de-energised as possible.

The nozzle loads introduced into the device through connected piping must not impair the device in any operating phase. Piping must be designed and installed in such a way that impermissible forces are avoided (e.g. by installing expansion joints or setting fixed points immediately before the transition to the connection points on the device).

Storage:

Ambient temperature min./max: -18 °C/40 °C

Storage must be protected from precipitation and direct sunlight.

Operation:

The device should only be installed in enclosed indoor areas of buildings. The ambient temperature in the installation room must be between +5°C and +40°C from the time the device is first filled with the system medium until it is taken out of service.

Sufficiently bright electrical lighting must be provided for the display and safety equipment, the operating devices and the access routes. Objects that are not intended for the operation or maintenance of the pressurisation system must not be stored in the immediate vicinity of the system (observe construction and safety regulations).

Integration into the system return is carried out according to the diagrams (in Chapter 5 - "Hydraulic connection diagrams").

Our pressurisation devices are suitable for systems where the maximum temperature at the connection point does not exceed 70 °C. If temperatures of more than +70 °C may occur at the point of integration into the system, a cooling vessel must be used (see chapter 4.4 "Use of cooling vessels"). The connection to the system return must be made at a point where there are no external hydraulic pressures that could influence the proper functioning of the system.

The expansion line is sized in accordance with ÖNORM H5151-1. See Appendix 11.1.



INFORMATION

We recommend connecting the pressurisation unit with a minimum dimension of DN25.



CAUTION

Danger of damage due to stray welding currents during installation with electric welding processes! If the welding current return cable is connected incorrectly to the part of the system to be welded, welding current may flow via the protective earth conductor. This can destroy protective conductors, damage devices and electrical equipment, overheat components and cause fires!

4.2. SpiroExpand PicoControl EPCF backfeed module

Devices in the SpiroExpand PicoControl series are supplied ex works without an EPCF backfeed module. Retrofitting is possible at any time. This module is installed in accordance with the instructions supplied with the module.

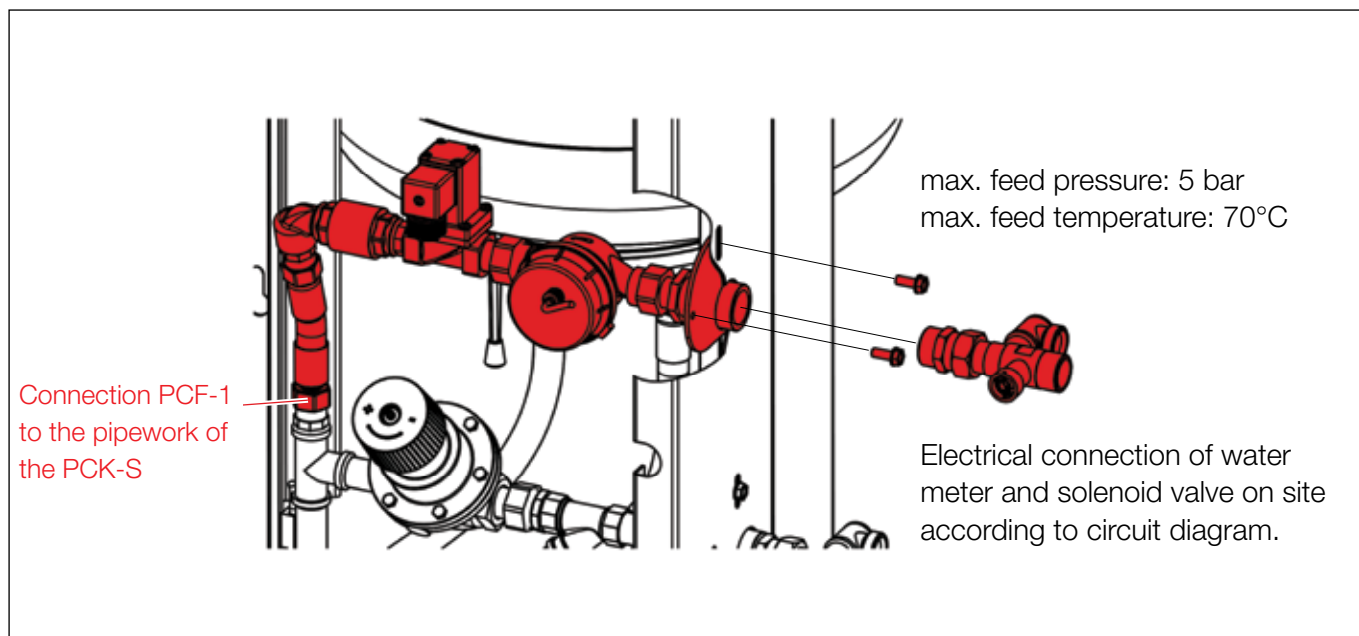

Figure 6: SpiroExpand PicoControl EPCF backfeed module



WARNING

The device must be de-energised before carrying out any electrical work!

4.3. Connection to the water supply system

Devices with a built-in backfeed module (EPCF) are equipped with a connection for fresh water supply.

If the fresh water connection is connected to the public water supply system, non-drinking water (heating water) must be prevented from being siphoned back into the water supply system.

Appropriate devices that reliably prevent back siphoning are not built into the SpiroExpand PicoControl Compact device and must be provided externally (on site) (e.g. system separator).

Connection conditions fresh water connection:

- highest inlet water pressure: 0.6 MPa = 6 bar
- lowest inlet water pressure: 0.2 Mpa = 2 bar

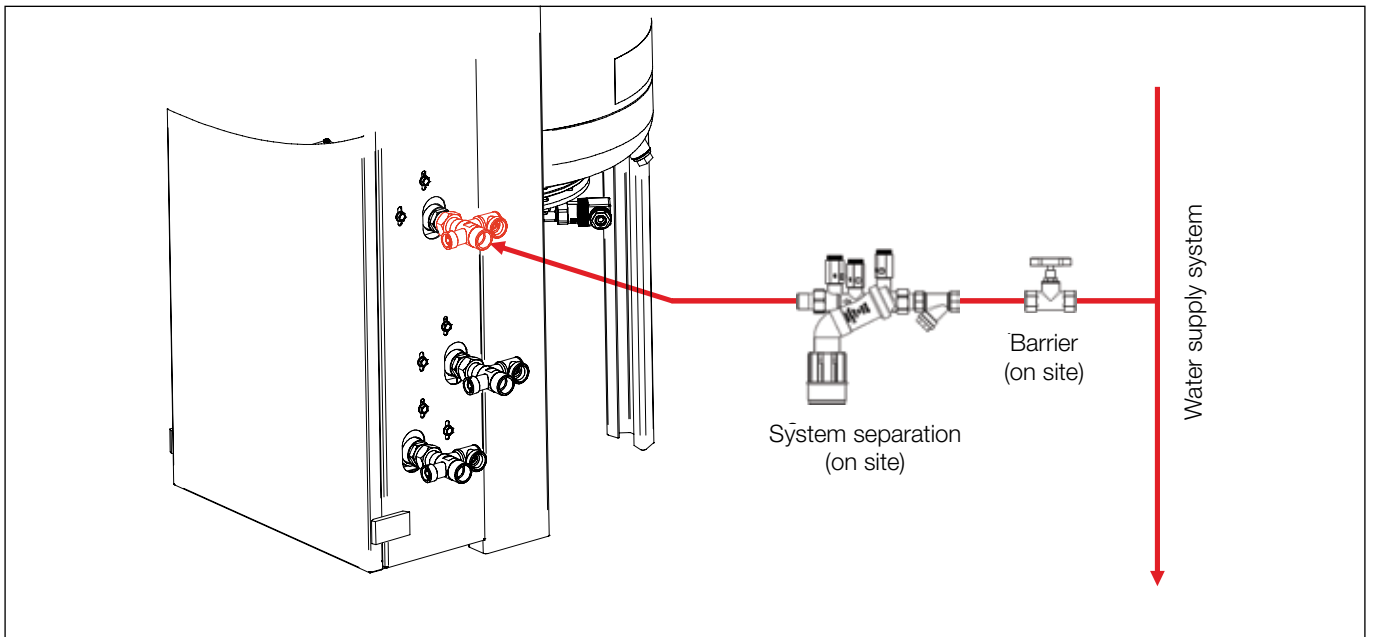

Figure 7: Connection to water supply system



WARNING

Devices intended for connection to the water supply system must be fitted on site with devices that reliably prevent non-drinking water from being siphoned back into the water supply system.

4.4. Use of cooling vessels

SpiroExpand PicoControl Compact-devices are suitable for systems where the maximum temperature at the connection point does not exceed 70 °C.

If temperatures of more than +70 °C (up to +110 °C) can occur at the point of integration into the system, a cooling vessel must be used.

Depending on the pipe routing from the system return to the EV cooling vessel, a vent valve must be installed on the upper connection. This must be vented once during commissioning.

i NOTE

When using an EV cooling vessel, ensure that it is not thermally insulated under any circumstances. This also applies to the entire expansion line from the system return to the automatic expansion valve.

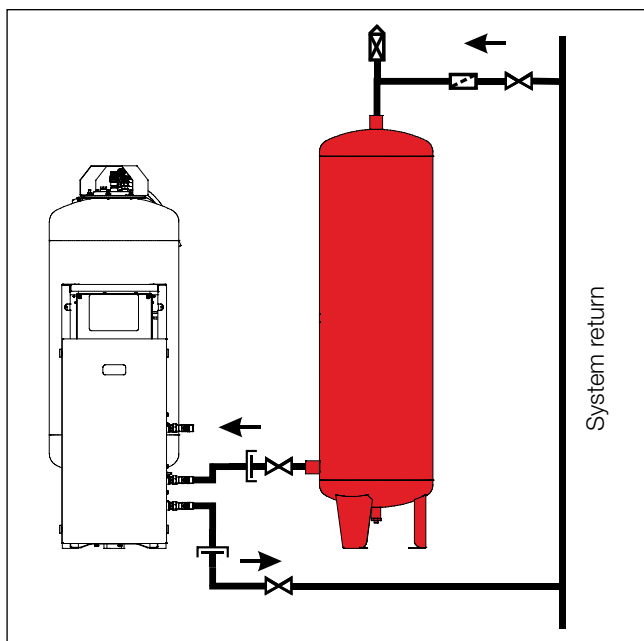

Figure 8: Use of an EV cooling vessel

4.5. Temperature sensor T2

SpiroExpand PicoControl devices, in conjunction with the T2 temperature sensor available as an accessory, offer the option of monitoring the temperature in the system return or in the expansion overflow pipe. This monitoring function is used to protect the device by blocking the degassing function if the temperature is currently too high, so that the fittings and the diaphragm are not damaged during the degassing process by system medium that is too hot or has not yet cooled down. The installation of a T2 temperature sensor is highly recommended for systems with a protection temperature of more than 95 °C.

This temperature sensor is integrated on site in the system return immediately upstream of the connection point (Fig. 9). When using an cooling vessel, a sleeve is provided on the cooling vessel for this purpose (Fig. 10).

i INFORMATION

When using an EV cooling vessel, ensure that it is not thermally insulated under any circumstances. This also applies to the entire expansion line from the system return to the automatic expansion valve.

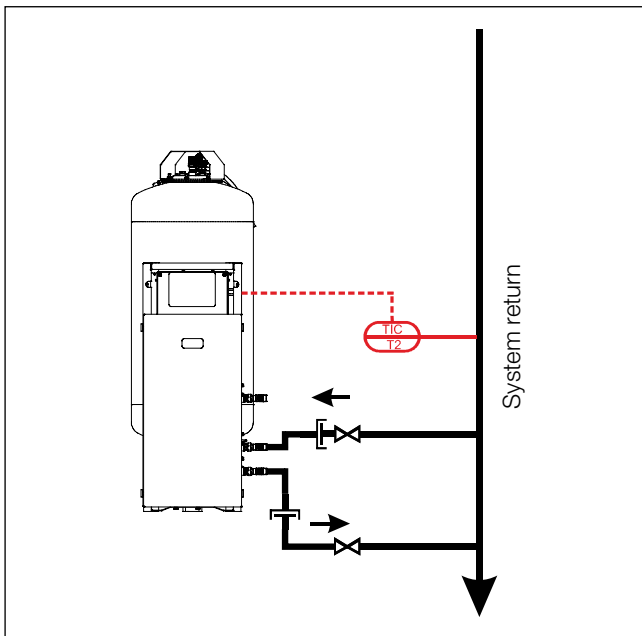

Figure 9: Integration of temperature sensor T2 without cooling vessel

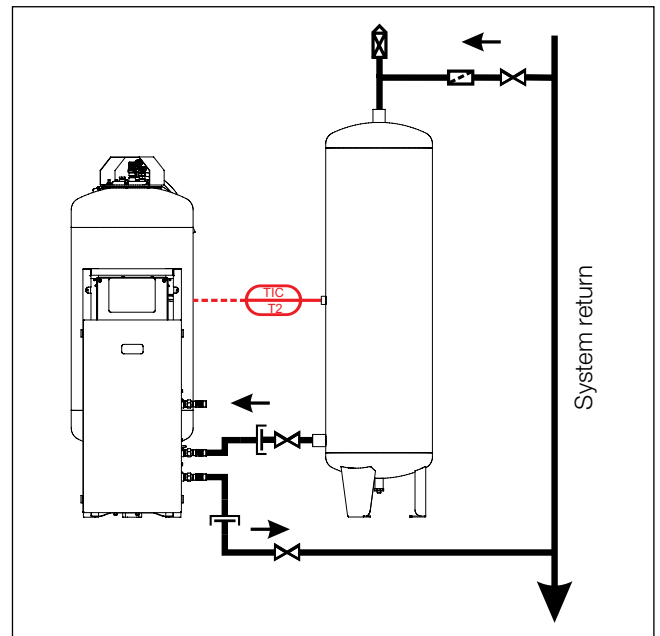

Figure 10: Integration of temperature sensor T2 with cooling vessel

4.6. Electrical connection

The mains supply cable is designed as a protective contact supply cable and should be connected by plugging it into a protective contact socket. This plug is intended for complete disconnection of the device from the mains; no other disconnecting devices are included.

If a direct connection to the mains is required, an appropriate device must be installed on site to enable complete disconnection from the mains (e.g. two-pole main switch).

The device must be secured on site and connected to an external all-pole mains switch. Ensure that the electrical data specified on the rating plate matches the existing power supply.

The device must be connected to the equipotential bonding before commissioning. A corresponding connection point is provided on the device and labelled accordingly.

Phase, neutral conductor

Both when connecting to the earthed socket and when connecting directly to the mains, ensure that the phase and neutral conductors are not interchanged. A corresponding check must be carried out by a suitably trained electrician as part of the electrical installation.

The phase and neutral conductor are connected correctly if no voltage is measured between the earthing busbar and neutral conductor busbar when the power supply is connected (the earthing and neutral conductor busbars are located in the SpiroExpand PicoControl Compact device's switch cabinet).

If a voltage equal to the supply voltage (approx. 230V~) is measured during this check, the phase and neutral conductors must be connected reversed and the polarity reversed accordingly.

INFORMATION

The polarity of the phase and neutral conductors must always be reversed externally to the SpiroExpand PicoControl device (if connected to an earthed socket, the phase and neutral conductors must be swapped in the socket).

CAUTION

If the mains connection cable of this device is damaged, it must be replaced by the manufacturer or its customer service or a similarly qualified person in order to avoid hazards.

WARNING

The applicable electrical regulations must be observed and complied with!

NOTE

The electrical connection values can be found on the type plate of the device.

5. HYDRAULIC CONNECTION DIAGRAMS

5.1. SpiroExpand PicoControl Compact EPCK with degassing function (standard scheme):

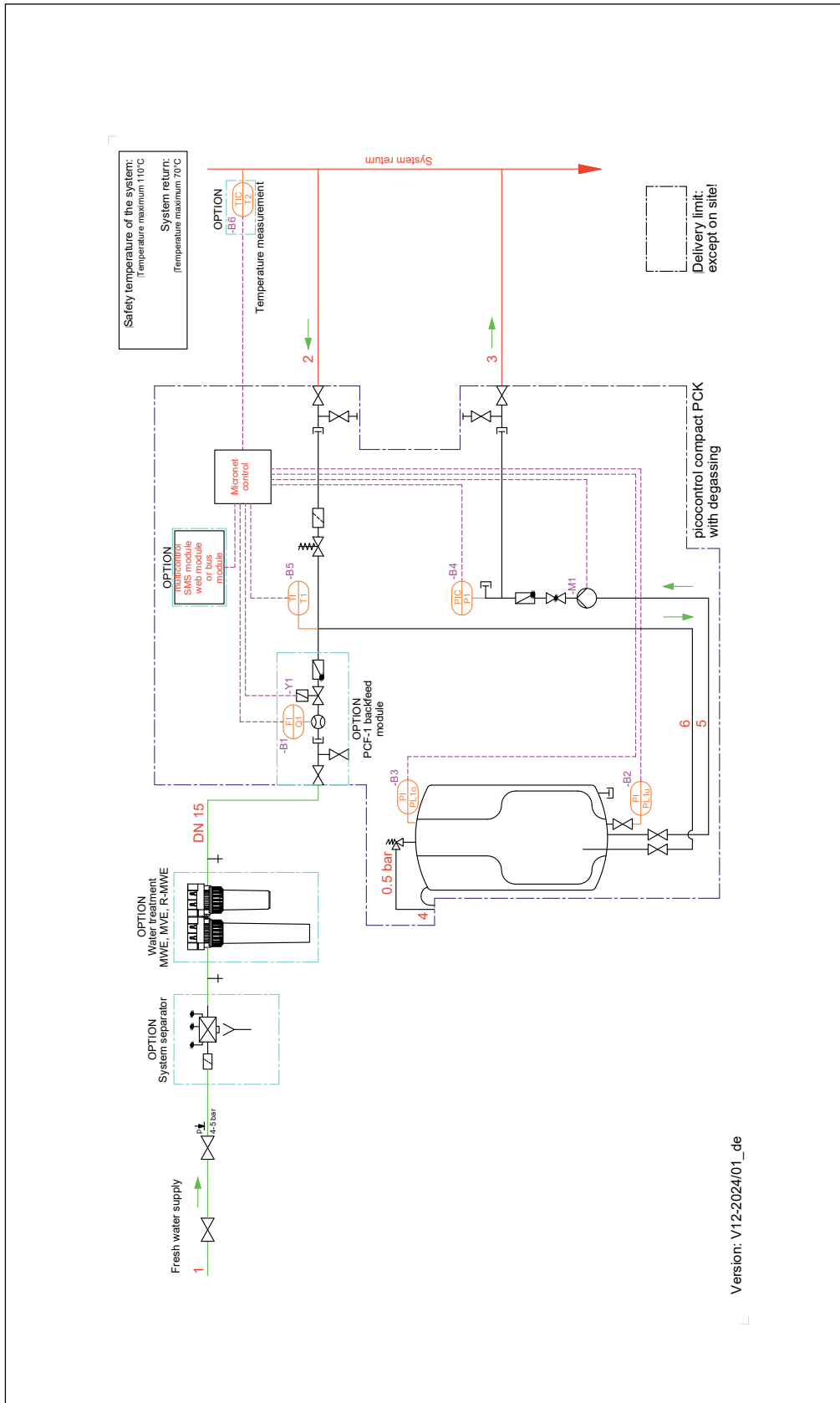

1. Fresh water supply	4. Drain funnel Container safety valve
2. Expansion overflow line (from the system return)	5. Suction line (from the expansion tank)
3. Expansion pressure line (to the system return)	6. Overflow line (to the expansion tank)

Options:

SMS module, web module, bus module, EPCF-1 backfeed module, water treatment, system separator, sensor T2

5.2. SpiroExpand PicoControl compact EPCK without degassing function:

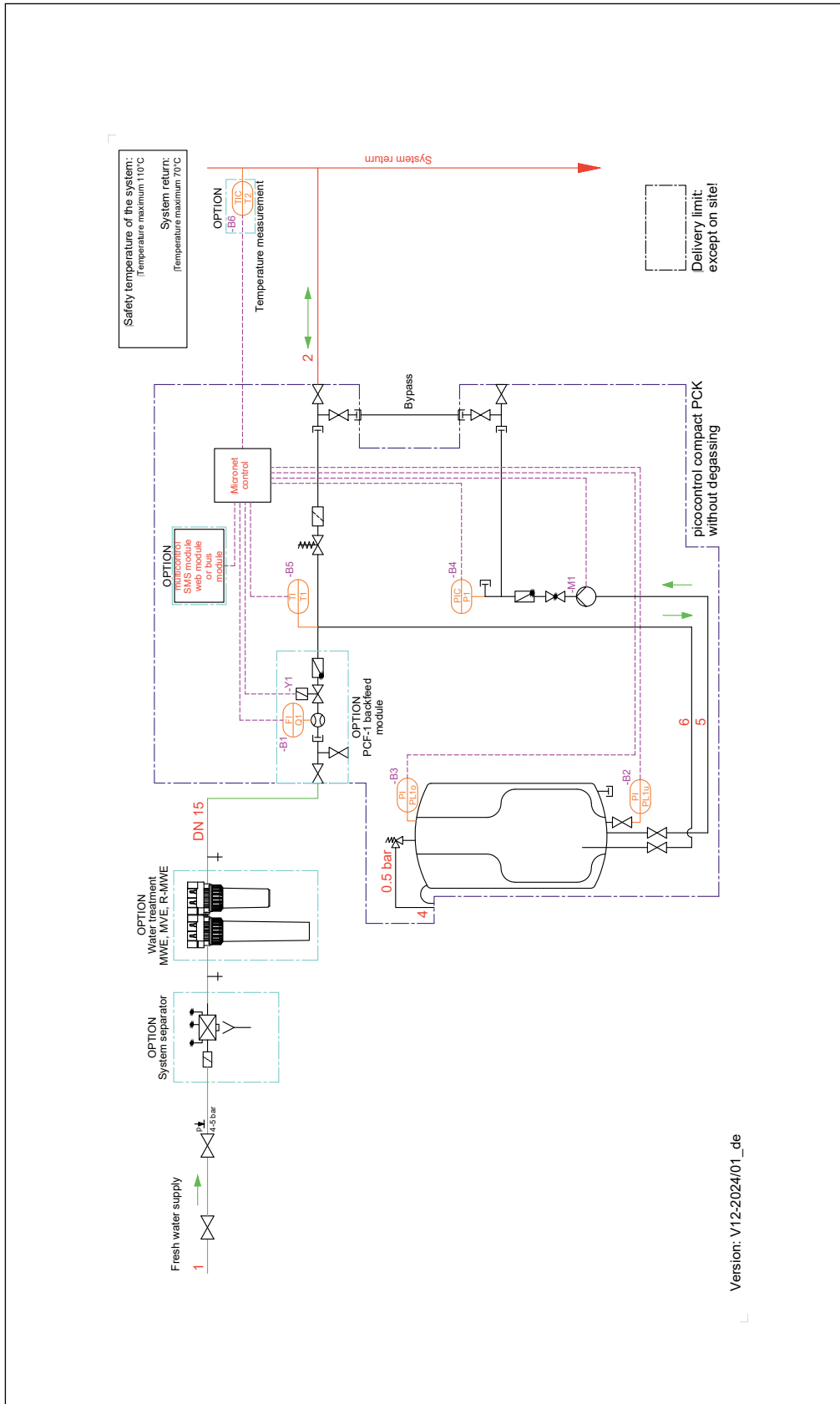

1. Fresh water supply	4. Drain funnel Container safety valve
2. Expansion overflow line (from the system return)	5. Suction line (from the expansion tank)
3. Expansion pressure line (to the system return)	6. Overflow line (to the expansion tank)

Options:

SMS module, web module, bus module, EPCF-1 backfeed module, water treatment, system separator, sensor T2, bypass (on site)

5.3. SpiroExpand PicoControl compact EPCK with degassing function with cooling vessel:

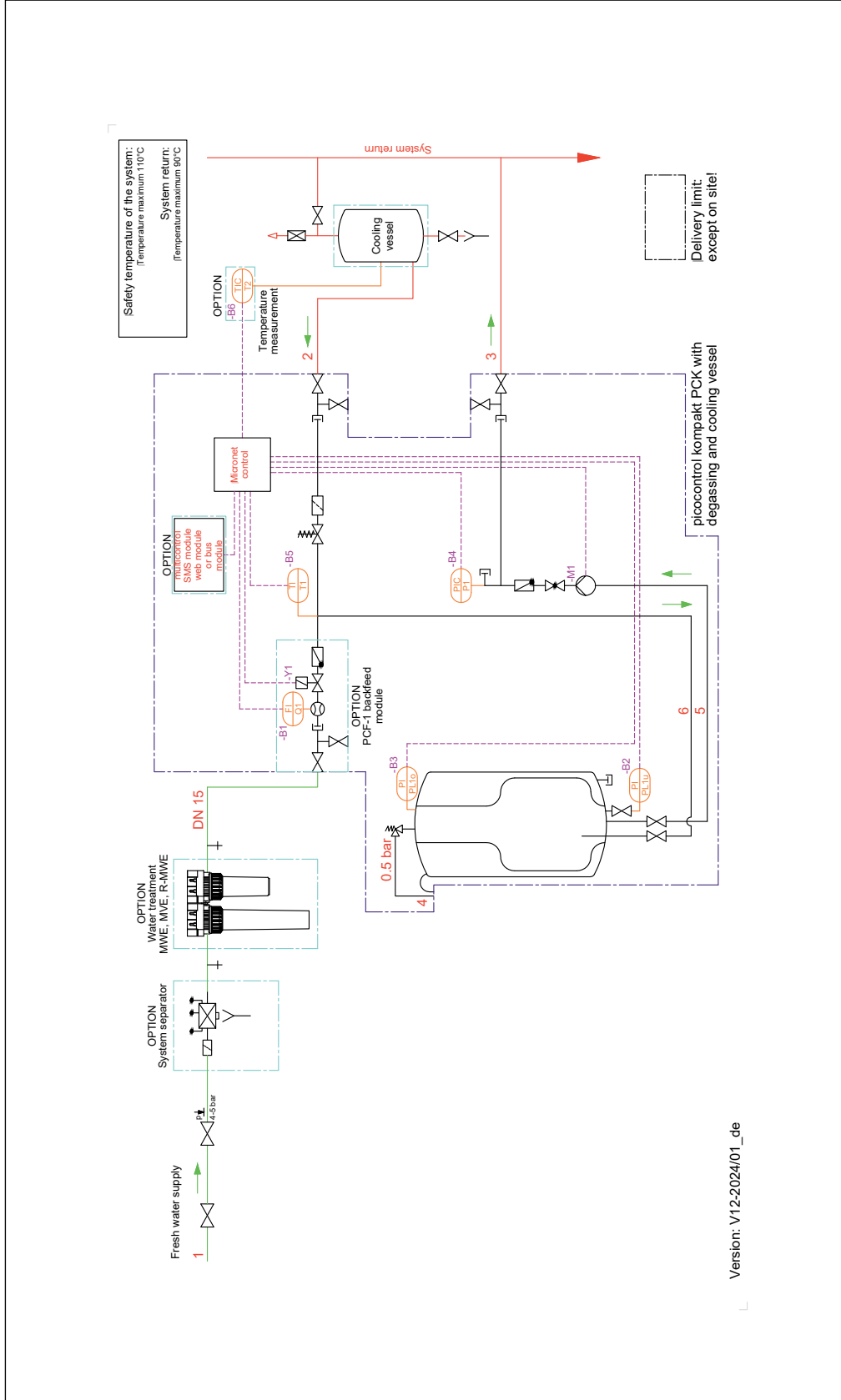

1. Fresh water supply	4. Drain funnel Container safety valve
2. Expansion overflow line (from the system return)	5. Suction line (from the expansion tank)
3. Expansion pressure line (to the system return)	6. Overflow line (to the expansion tank)

Options: SMS module, bus module, EPCF-1 backfeed module, water treatment, system separator, sensor T2, EV cooling vessel

6. CIRCUIT DIAGRAMS

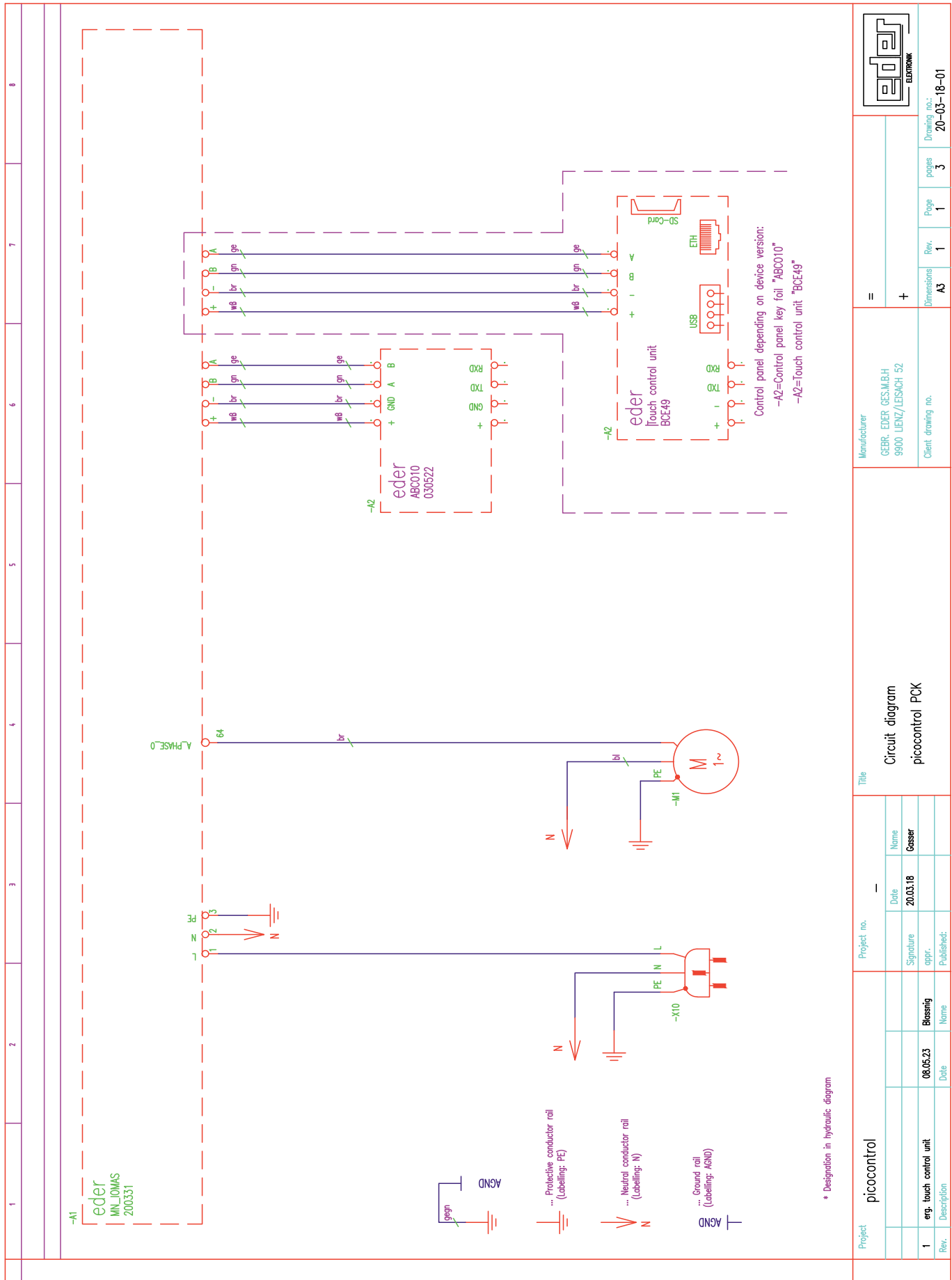

Project		picocontrol		Project no.		-		Title		Circuit diagram picocontrol PCK	
Rev.		Description		Signature		Date		Name		Manufacturer	
1		erg. touch control unit		Blessing		20.03.18		Gasser		GERR EDER GES.M.B.H 9900 LIENZ/LEISCH 52	
Rev.		Date		Published:		Date		Name		Client drawing no.	
1		08.05.23								A3	
Rev.		Page		Dimensions		Page		Pages		Drawing no.	
1		1		A3		1		3		20-03-18-01	



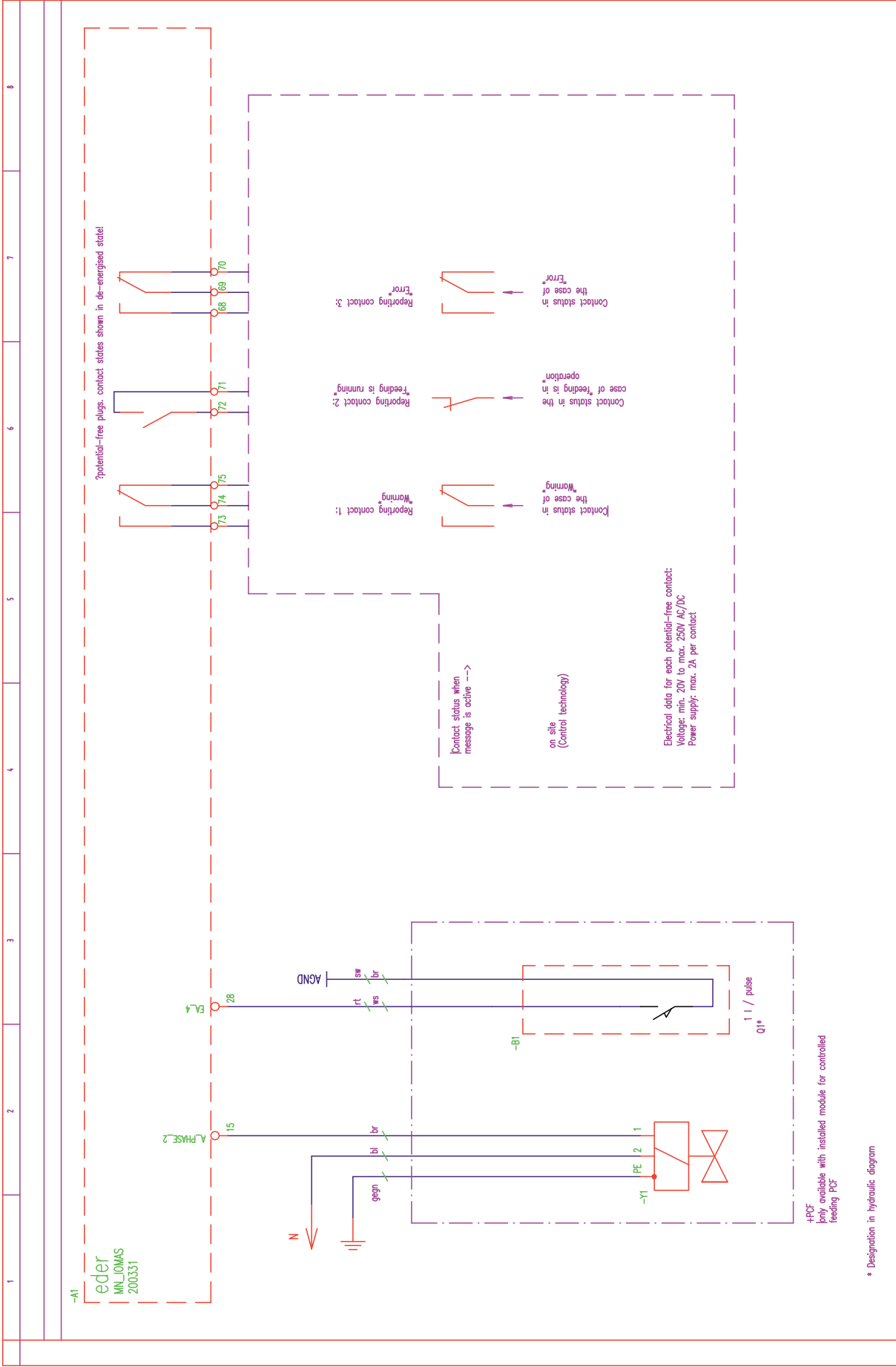

Project		picocontrol		Project no.		-	
Title		Circuit diagram picocontrol PCK		Manufacturer		GERB EDER GES.M.B.H 9900 LIENZ/LEISCH 52	
Date		20.03.18		Client drawing no.		A3	
Signature		Blossing		Rev.		0	
Name		Blossing		Page		2	
Date		28.06.24		pages		3	
Drawing no.		20-03-18-07		Dimensions		A3	



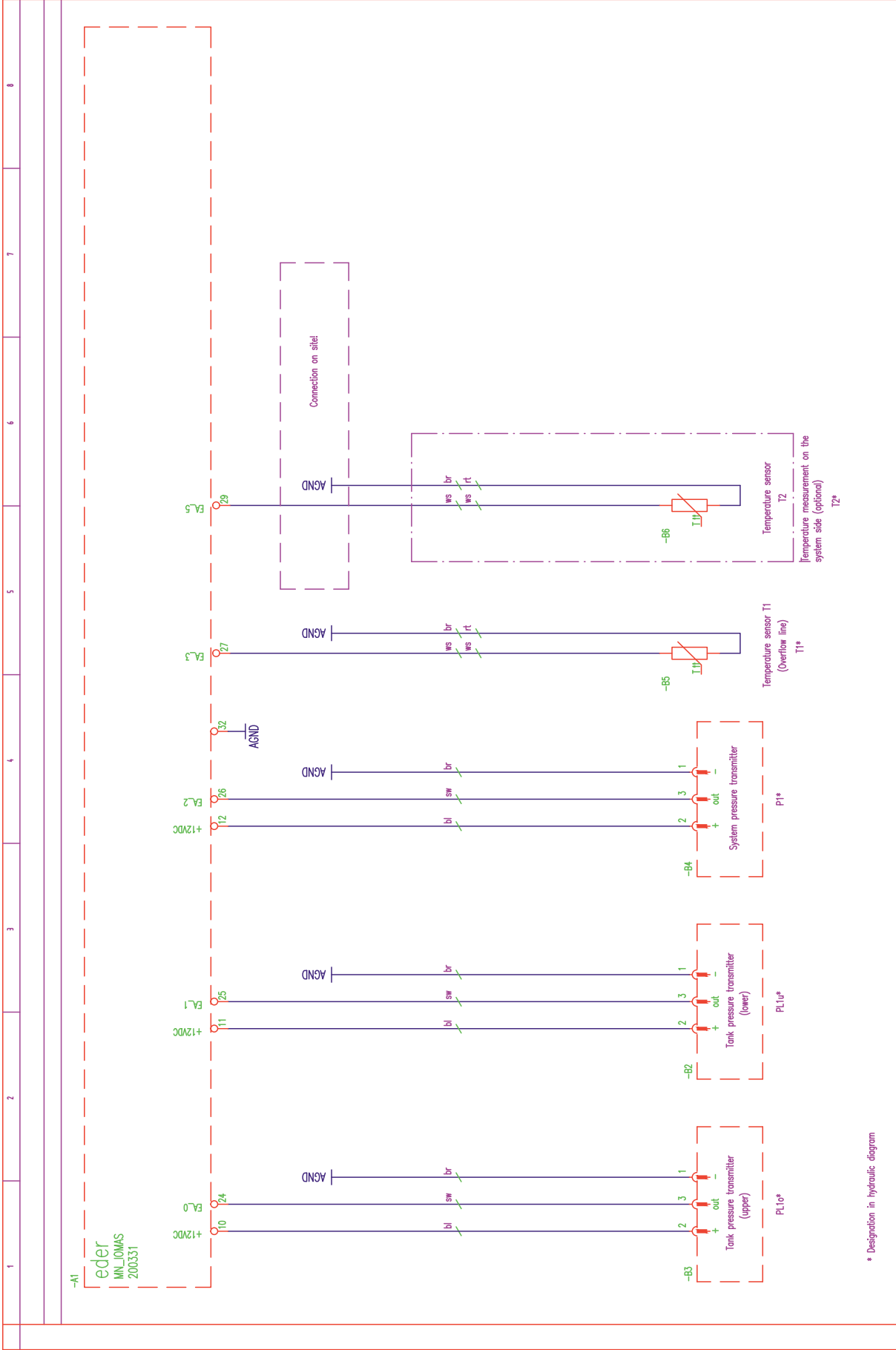

* Designation in hydraulic diagram

Project		Project no.		Title	
picocontrol		-		Circuit diagram picocontrol PCK	
Signature		Date		Name	
app.		20.03.18		Gesser	
Description		Name		Date	
-		-		-	
Dimensions		Rev.		Page	
A3		0		3	
Manufacturer		Client drawing no.		pages	
GERB EDER GES.M.B.H 9900 LIENZ/LEISCH 52		-		3	
Drawing no.:		20-03-18-03			



LEGEND SPIROEXPAND PICOCONTROL EPCK

Designation	Description
-A1	Spirotech control electronics: SpiroExpand PicoControl motherboard, type 200331 (alternatively also suitable: MultiControl motherboard, type 200331)
-A2	depending on device version: Spirotech control electronics: MultiControl processor board, type ABCO10 Spirotech Control electronics: Touchscreen operating unit, type BCE49
-M1	Motor pump 1
-Y1	EPCF backfeed module: Solenoid valve (OPTION)
-B1	EPCF backfeed module: Water meter pulse output (OPTION)
-B2	Vessel pressure transmitter bottom (PL1u*)
-B3	Vessel pressure transmitter top (PL1o*)
-B4	System pressure transmitter (P1*)
-B5	Temperature sensor (T1*), sensor element KTY10-6 or compatible
-B6	Temperature sensor (T2*), sensor element KTY10-6 or compatible

7. COMMISSIONING

i NOTE

Commissioning of the device by the Spirotech factory customer service or an authorised partner, including training of the operating personnel of the system, is mandatory!

Proceed as follows when commissioning the MultiControl Compact and MultiControl Modular:

Steps 1-3 represent work to be carried out on site in preparation for commissioning.

Step 1

Determining the upper working pressure The upper working pressure is also the set pressure at the overflow valve.

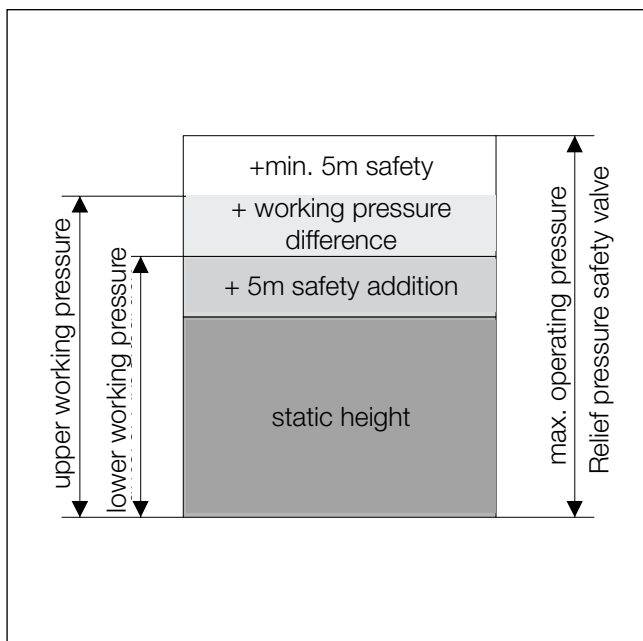

Figure 11: Determination of upper and lower working pressure

Step 2

Shut off the lines from/to the system (expansion overflow line, expansion pressure line, fresh water supply).

Step 3

Fill and ventilate the system to the upper working pressure determined in step 1.

Step 4

Check the hydraulic and electrical connections for correctness, especially the expansion pressure and expansion overflow line and flow direction at the point of integration.

Step 5

Check the inlet pressure at the connection point of the EPCF backfeed module (the maximum inlet pressure is 5 bar).

Step 6

Switch on the power supply and check whether the device function is deactivated. If necessary, switch off the device function using the activate device function button (system ON/OFF).

Step 7

Device setup of the SpiroExpand PicoControl electronics (touchscreen operating unit) Note! Settings in the device setup allow the touchscreen operating unit to be customised to the components in the device and its range of functions. Some of the settings possible in the device setup have already been preconfigured in the factory. Further settings are made during commissioning or, if necessary, in the course of a component extension or component replacement (service/maintenance).

i NOTE

Device setup: see touchscreen operating unit operating instructions, menu "Settings" → "Device set-up".

Step 8

Filling and venting the pressurising pump and the piping.

- Fully open the shut-off valves on the pump pressure side (1) (open ex works)
- Remove the plug from the pressure transmitter section (2)
- With the EPCF backfeed module installed, switch to manual mode (operating level 3: Manual mode -> Outputs). Switch on the "backfeed valve" output and fill the tank with it until a continuous jet of the system medium emerges at the pressure transmitter section, then set the "backfeed valve" output back to automatic mode (Auto "1"). As a guideline, a vessel level of approx. 30-40% can be assumed here, at which the pump should be filled. During this filling process, the vessel level can be monitored in the basic display.

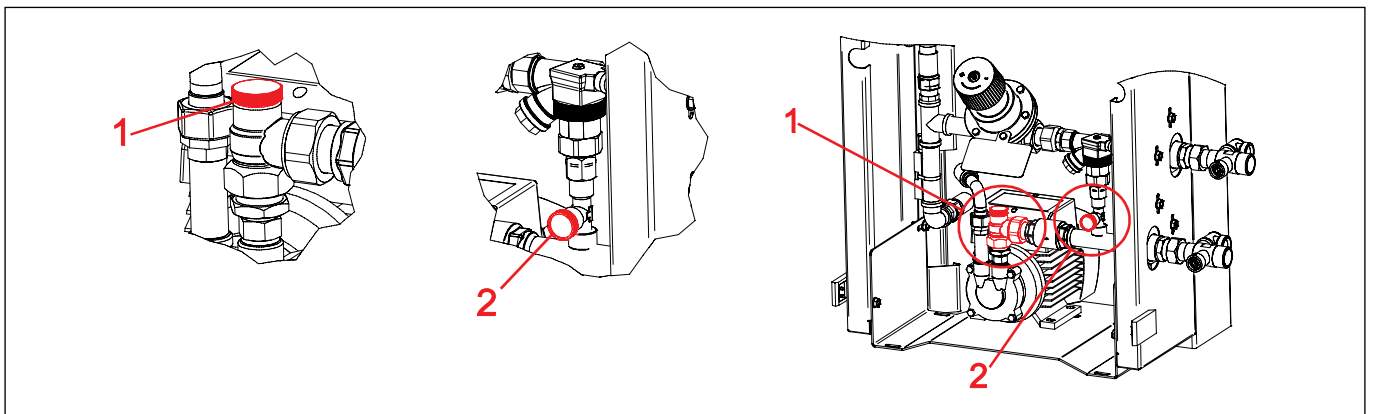

Figure 12: Filling and venting the pressurising pump and the piping.

Step 9

Once the basic configuration has been completed, use the Activate device function button to switch on the device function (device ON/OFF).

Step 10

Adjusting the pressurising pump.

Depending on the working pressure to be set, it may be necessary to adjust the pressure maintenance pump on the pressure side (characteristic curve-dependent increase in delivery rate with decreasing pressure).

An indication that adjustment is necessary may be, for example, if the overflow valve only closes completely at more than approx. 0.5 bar below the upper working pressure after the pump has been switched off.

i NOTE

The pressurising pump must always be adjusted before the working pressure is set. After this, neither the working pressure nor the adjustment may be changed! If the pump is subsequently adjusted, the working pressure must be set again.

Step 11

Set the working pressure

- Open the shut-off valves from/to the system (expansion overflow pipe, expansion pressure line, fresh water).
Depending on the size of the system, the pressure setting can take a long time, as the pressure must be propagated throughout the entire connected system in order to be sufficiently stable for the setting.
- Switch to operating level 3

i NOTE

The connection from/to the system must be guaranteed for adjustment!

- "Settings" → "Pressure maintenance" → "Working pressure"
- The current setting is displayed; it corresponds to the last set working pressure (e.g. factory-set default values).

! WARNING

Depending on the values displayed, the working pressure must always be set again during commissioning!

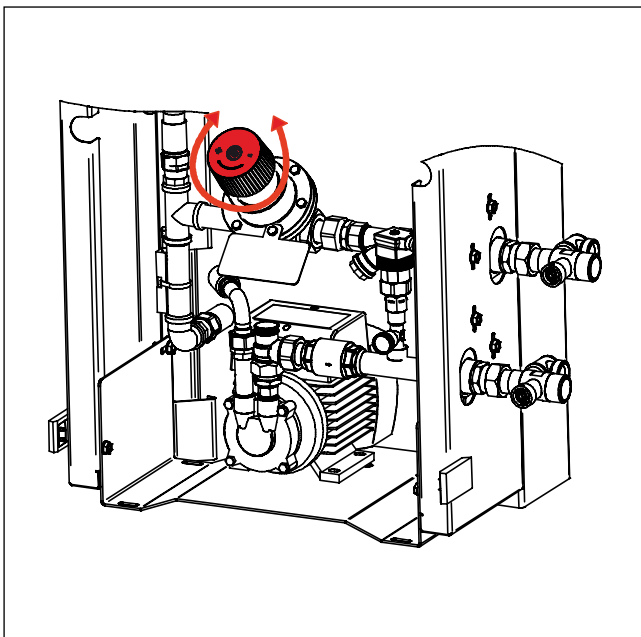

Figure 13: Determination of upper and lower working pressure

- After pressing the "CHANGE" button and confirming with "YES", the pump starts and the working pressure setting is active.
- Set the overflow valve to the upper working pressure determined in step 1.
The currently measured pressure is shown on the display. Setpoint adjustment on the valve with black handwheel clockwise = higher pressure, anti-clockwise = lower pressure.
- Once the working pressure has been adjusted to the desired value and has stabilised, set the switching differential and accept the pressure setting using the OK button.

Step 12

If the EPCF backfeed module is installed, the operating mode of the backfeed module must be selected.

This operating mode depends on various factors, such as the size of the system, the age of the system, any known leaks, etc.

In the case of known regular leaks (e.g. if it is known that a certain quantity needs to be refilled within a certain time), we recommend the "time-controlled" operating mode.

The description of the possible EPCF operating modes can be found in the operating instructions for the touchscreen operating unit.

Step 13

The device is ready for operation.

The shut-off valves in the pipes from/to the system must be secured against unintentional closing.

Further settings (e.g. softening MWE, operating modes, etc.) can be made in the "Settings" menu.

8. MAINTENANCE

8.1. Cleaning

During operation, dirt particles are separated from the system at the built-in strainer. These impurities are gathered in the strainer and are consequently lead to the reduced passage of the strainer. This may cause problems with the function of the device.

NOTE

Recommendation: If problems with contamination occur frequently or constantly, further measures should be considered for the system (e.g. replacement and flushing of the system contents, installation of additional filters or sludge separators, etc.). These measures have a positive effect on all installed devices with direct contact with the medium, not just the pressurisation system.

The dirt particles separated by the strainer must therefore be removed at regular intervals by removing and cleaning the strainer screen. This inspection and cleaning of the strainer must be carried out at least twice a year! However, if there are any problems with the function of the device, the strainer must be cleaned first of all! Problems and malfunctions caused by failure to clean the strainer as prescribed are excluded from any warranty claims.

8.2. Maintenance

The device must undergo maintenance at least once a year or when a warning "W03" is displayed! Carrying out this maintenance is the responsibility of the operator.

WARNING

If the operator of the system is unable or unwilling to carry out this annual maintenance, appropriate specialist personnel or the Spirotech factory customer service must be commissioned to do so.

NOTE

It is recommended that maintenance is carried out by Spirotech's customer service centre. The conclusion of a maintenance contract is highly recommended.

Problems or malfunctions caused by non-compliance with the prescribed maintenance intervals or lack of maintenance are excluded from any warranty.

Work to be carried out in the course of maintenance:

- Check and document whether the regular cleaning according to 8.1 is carried out and document when this was last done; Carry out cleaning in any case!
- Check the check valve(s) for correct closure.
- Check the overflow valve for correct function and correct closing.
- Desludging: Remove the plastic plug of the pressure transmitter section from the lower tank flange and allow the medium to flow out for a short time. Any impurities that may be present are thus flushed out. Screw the plastic plug back in (the ball valve installed in the pressure transmitter section can be used to control medium flow).
- Open the drain plug on the side of the container base and check whether medium is flowing.
- Drain any medium that may be present. If fluid is constantly leaking, this could indicate a defect in the membrane: check!

9. SPARE PARTS LIST

9.1. Expansion tank

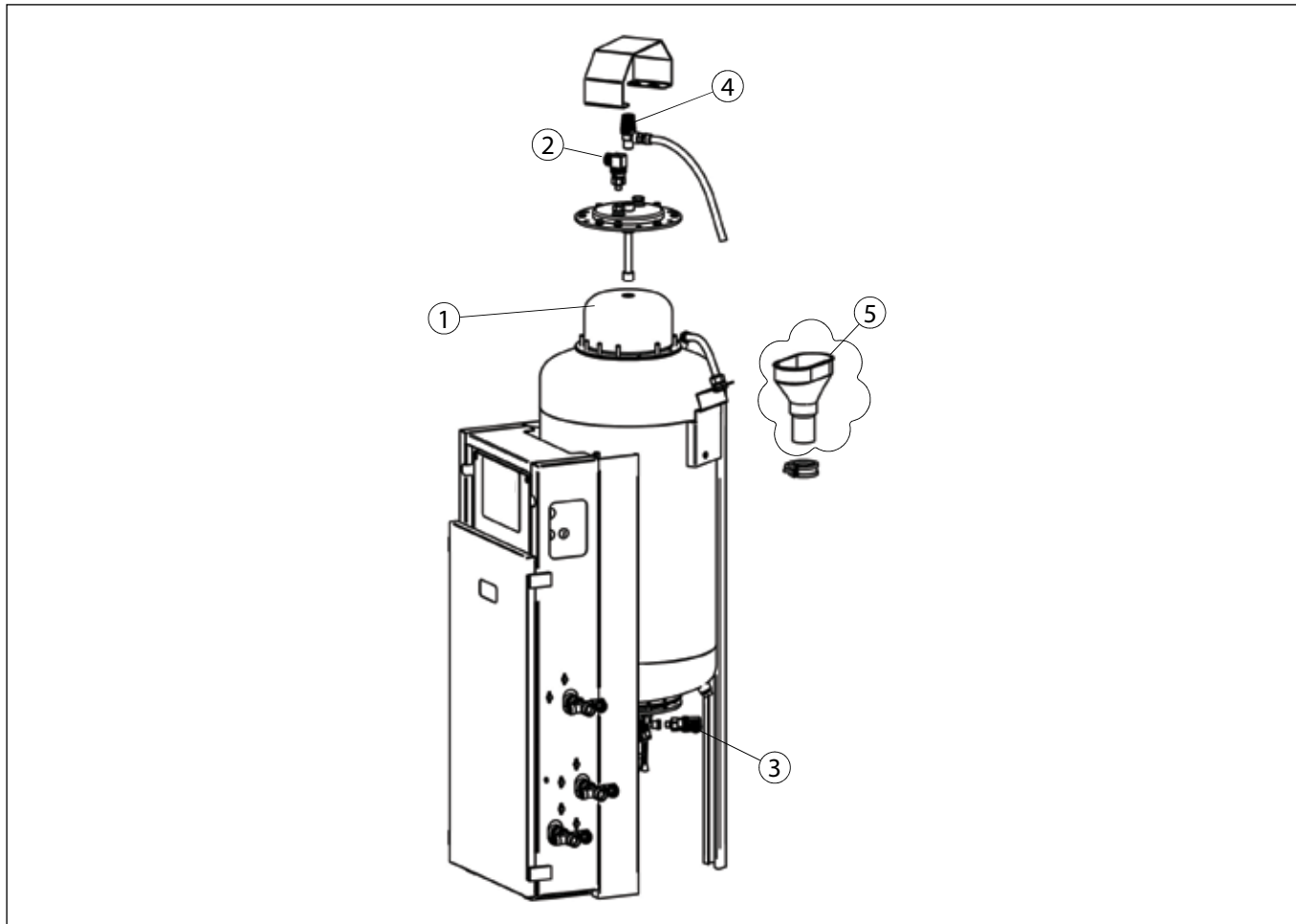

POS.	DESIGNATION	SPARE PART ART. NO.					
		PCL-S 45-4.0	PCK-S 75-4.0	EPCK-S 125-4.0	EPCK-S 200-4.0	EPCK-S 300-4.0	EPCK-S 500-4.0
1	Membrane	E90429	E90430	E90480	E90481	E90450	
2	Vessel pressure transmitter top				E90141		
3	Vessel pressure transmitter bottom				E90141		
4	Safety valve 0.5 bar				E90596		
5	Drain funnel 50				E90916		

9.2. Piping

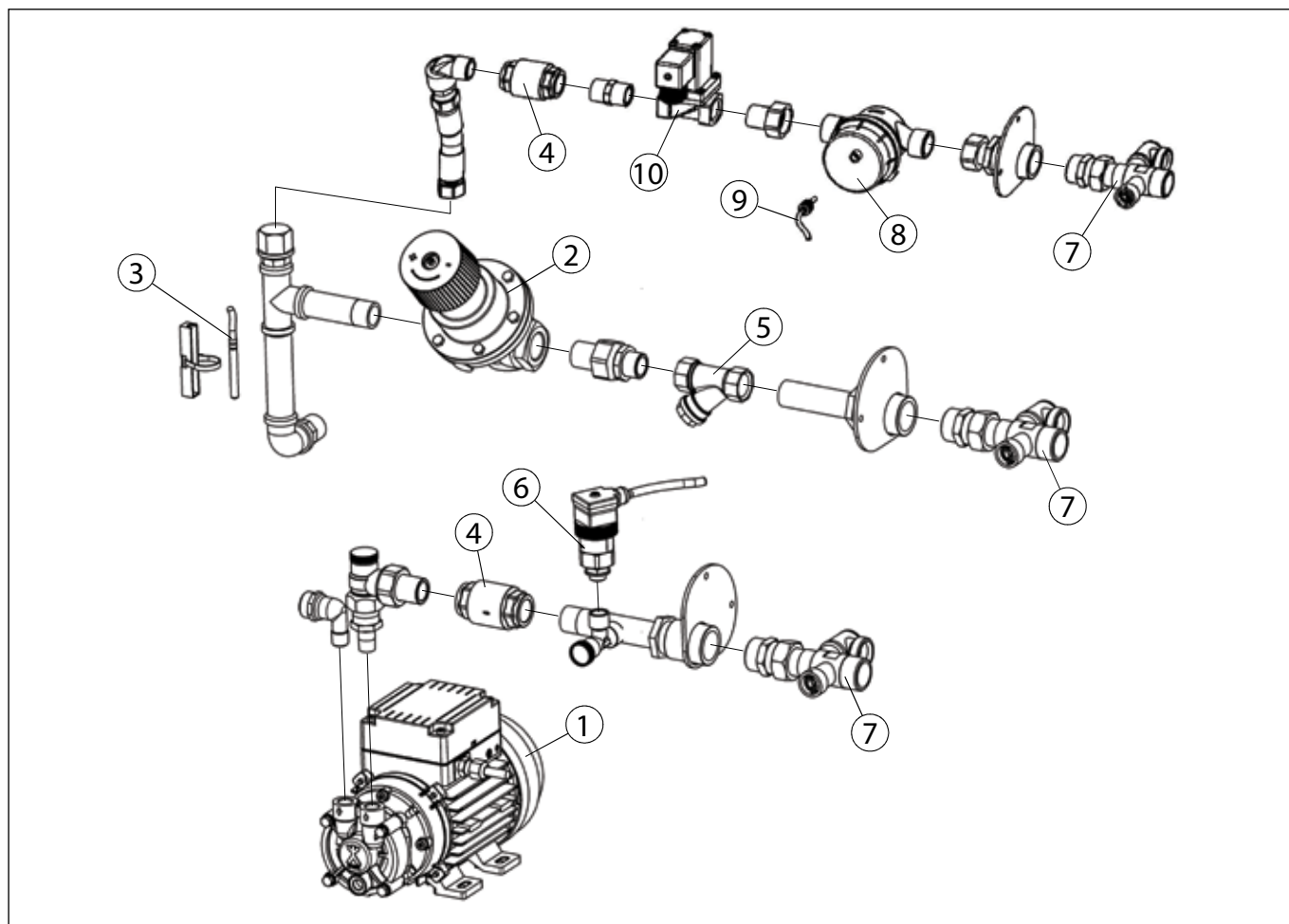

POS.	DESIGNATION	SPARE PART ART. NO.
		EPCK-S-4.0
1	Pump for EPCK-4.0, 1x230V~, 50Hz	E90975
2	Pressure stabilising valve - 44-6B, 1/2" (DN 15), 1-4 bar	E90699
3	Temperature sensor for MC	E90911
4	Non-return valve, 1/2"	E90620
5	Strainer, 1/2"	E90928
6	System pressure transmitter	E90140
7	Maintenance unit 3/4" a/a	E50110
8	Water meter 1.5 m³/h	E90950
9	Water meter contact module 1 litre/pulse, plug-in	E90949
10	Solenoid valve	E90575

9.3. Elektronik

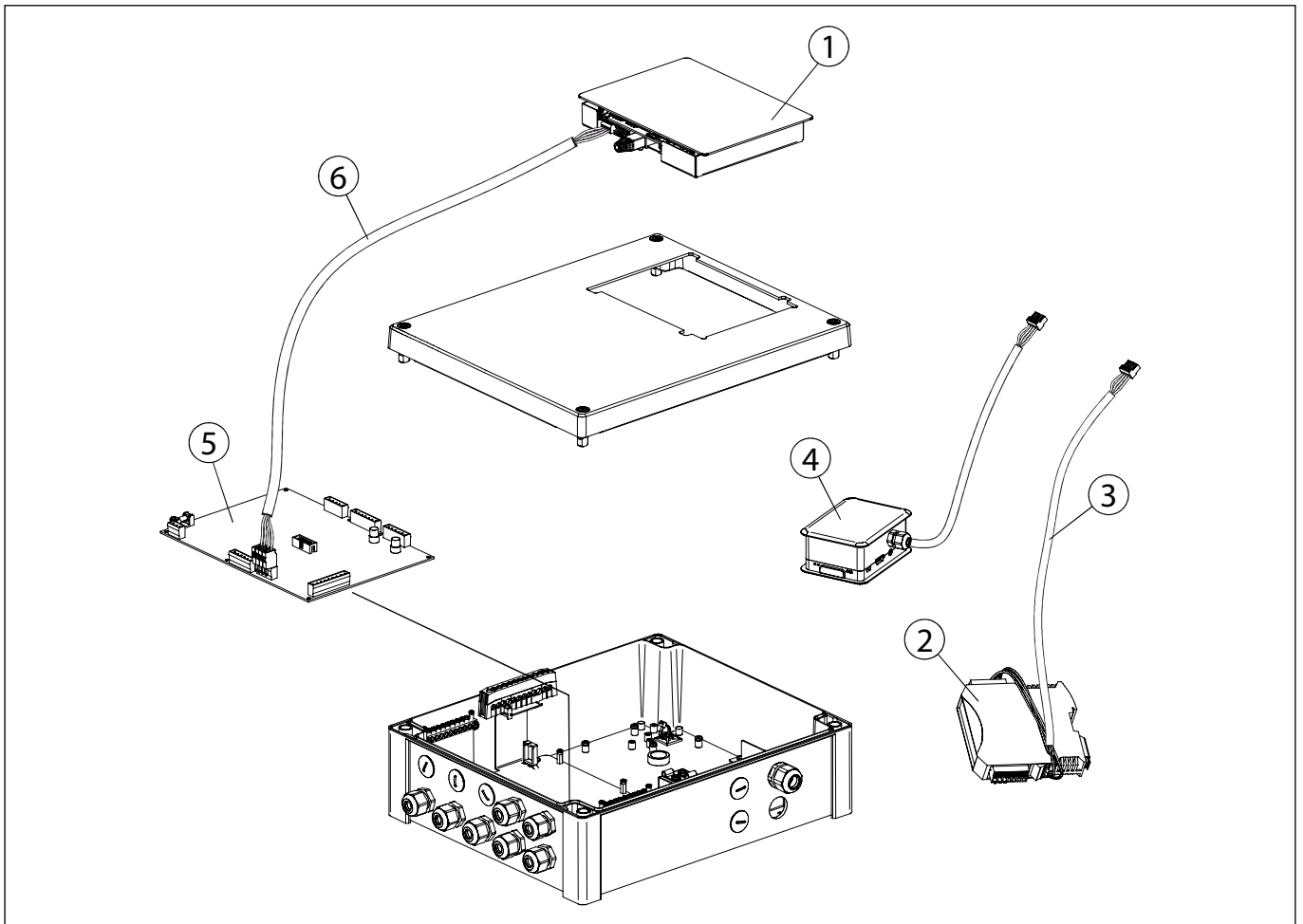

POS.	DESIGNATION	SPARE PART ART. NO.
		EPCK-S_-4.0
1	Touchscreen operating unit, type BCE49, incl. shielding plate	E90996
2	MultiControl Bus Module Profibus	(optionally available as an accessory)
2	MultiControl Bus Module Modbus RTU Rs485	(optionally available as an accessory)
2	MultiControl Profinet Bus Module	(optionally available as an accessory)
3	Connection cabling for bus module	(included in the scope of delivery of the bus module)
4	MultiControl web module	(optionally available as an accessory)
5	Print - MultiControl motherboard, type 200331	E90903
6	Cable - connecting cable, motherboard - touch control unit, 4-pin	E70083



WARNING

Simultaneous use of SMS module, bus module and web module not possible!

10. CERTIFICATES



EG-Konformitätserklärung EC Declaration of Conformity



im Sinne der Richtlinie(n):

- 2006/42/EG über Maschinen
- 2014/30/EU über die elektromagnetische Verträglichkeit
- 2014/35/EU über die Bereitstellung elektrischer Betriebsmittel zur Verwendung innerhalb bestimmter Spannungsgrenzen auf dem Markt
- 2011/65/EU Verwendung bestimmter gefährlicher Stoffe in Elektro- und Elektronikgeräten (RoHS 2) gemäß Anhang II (gültig ab 22.07.2019) nach Änderungen der Richtlinie (EU) 2015/863

in accordance with the directive(s):

- 2006/42/EC on machinery
- 2014/30/EU relating to electromagnetic compatibility
- 2014/35/EU relating to the making available on the market of electrical equipment designed for use within certain voltage limits
- 2011/65/EU use of certain hazardous substances in electrical and electronic equipment (RoHS 2) as per Annex II (valid from 22 July 2019) acc. to the amendments of the directive (EU) 2015/863

Der Hersteller

Eder Spirotech GmbH
Leisach 52
A - 9909 Leisach

The manufacturer

erklärt hiermit, dass das Produkt

picocontrol kompakt PCK

declares hereby, that the product

mit dem (optionalen) Zubehör

Nachspeisemodul

picocontrol PCF

with the (optional) accessories

makeup module

entwickelt, konstruiert und gefertigt wurde in Übereinstimmung mit der/den oben genannten Richtlinie(n).

has been developed, designed and manufactured in compliance with the above listed directive(s).

Folgende harmonisierten und nationalen Normen und Spezifikationen sind angewandt:

- ÖNORM EN ISO 12100:2013
- ÖVE EN 60204-1:2019
- EN 61000-6-2:2005
- EN 61000-6-3:2007 +A1:2011 +AC:2012
- EN 61326-1:2013
- EN 61000-3-2:2014
- EN 61000-3-3:2013
- ÖNORM EN 60335-1:2012 + AC:2014
- ÖVE ÖNORM EN 60730-1:2012

The following harmonised and national standards and specifications have been applied:

Leisach, 03.02.2022
Ort, Datum

Ing. Hans Jacobs, Geschäftsführer
Unterschrift

11. APPENDIX

11.1. Sizing the expansion line

Expansion lines are pipes that connect the system to the expansion and pressure maintenance system.

i NOTE

The design criterion is the nominal heat output to be dissipated, the maximum operating temperature and the flow velocity according to ÖNORM H 5151-1:2010 12 15.

Extract from ÖNORM H 5151-1:2010 12 15:

11.2.3.2 Sizing the expansion line
(expansion line).

The following points must be observed when sizing the expansion line:

- The nominal heat output of the heat supply system applies to the sizing of the expansion line.
- For systems with a nominal heat output of less than 500 kW, the minimum nominal diameters can be retrieved from the adjacent table.

DN	NOMINAL HEAT OUTPUT IN KW
20	up to 120
25	over 120 to 500

Minimum nominal diameter of expansion lines

The maximum flow velocity in the expansion line must not exceed 0.15 m/s.

i NOTE

If the heat supply and heat distribution systems are separated, there may be a small volume of water in the heat supply system. It may therefore be necessary to size the expansion line using the maximum flow velocity.

The calculation of the flow velocity in the expansion line must be based on the percentage temperature-dependent increase in volume V_0 from the filling water temperature (10°C) to the protection temperature θ_{TZ} and the total content of the system V_A .

The heating time t_A , which is required to reach the safety temperature θ_{TZ} and the total volume of the system V_A , is calculated according to equation A:

$$t_A = \frac{(V_A \cdot \Delta\theta_{TZ} \cdot c_W \cdot \rho_W)}{\Phi_N}$$

c_W	spec. heat capacity of heating water Θ_{TZ}	[kJ/(kg · K)]
Φ_N	Nominal heat output	[kW]
ρ_W	Density of the heating water Θ_{TZ}	[kg/m ³]

Figure 14: Equation A

The expansion volume flow \dot{V}_e is calculated according to equation B:

$$\dot{V}_e = \frac{V_e}{t_A \cdot 1000}$$

Figure 15: Equation B

The calculation inner diameter of the expansion line is calculated according to equation C:

$$d_{AI} = \sqrt{\frac{4 \cdot \dot{V}_e}{\pi \cdot v}} \cdot 1000$$

Figure 16: Equation C

The next larger nominal pipe diameter must be selected. The maximum pressure loss in the expansion line must not exceed 1 kPa.

i NOTE

Within the pressure maintenance system (overflow line, suction line), the manufacturer decides which flow velocities ensure problem-free functioning of the pressure maintenance system.

The maximum flow velocities are therefore 0.75 m/s in the overflow line and 0.50 m/s in the suction line.

MAXIMISING PERFORMANCE FOR YOU

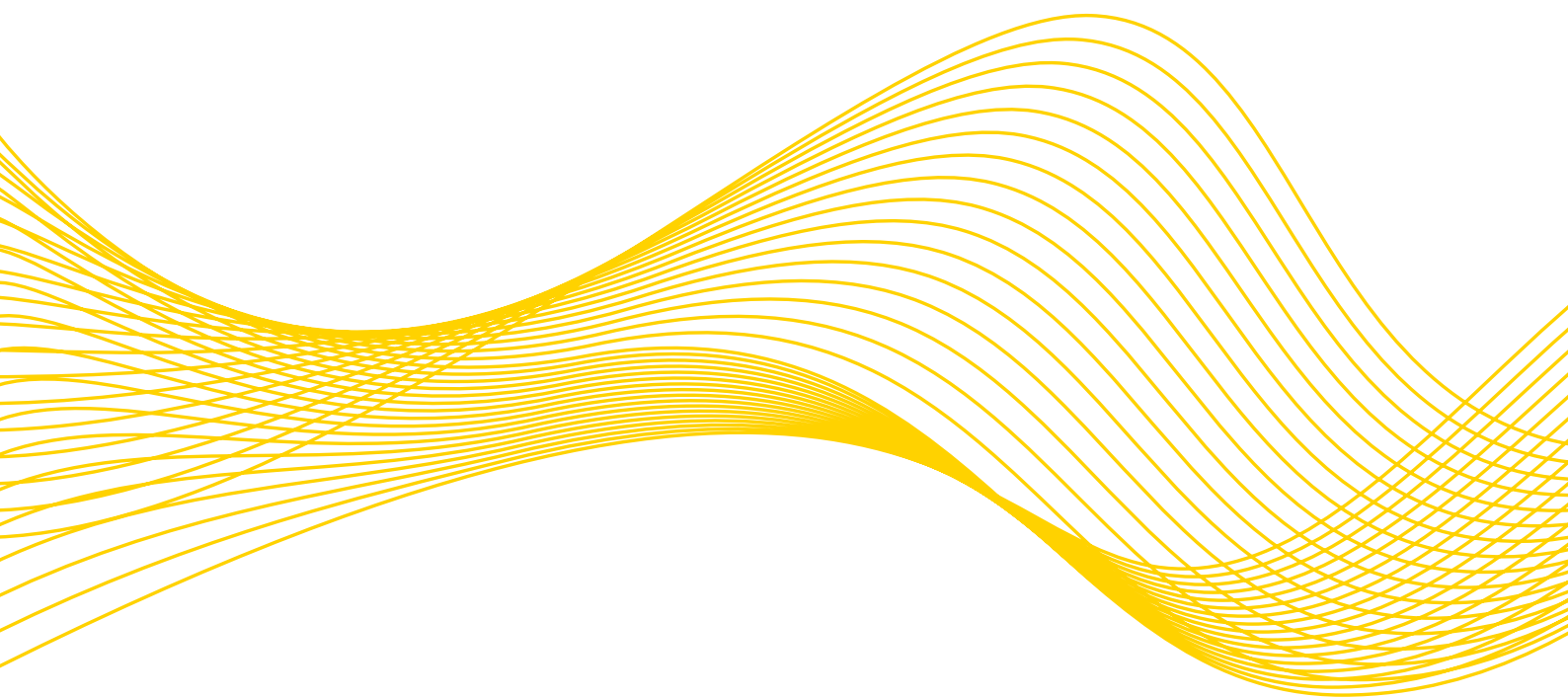

Copyright ©

All rights reserved. No part of this manual may be reproduced and/or published on the Internet, by means of printing, photocopying, microfilm or in any other way without the prior written permission of Spirotech bv.

Spirotech bv

Postbus 207

5700 AE Helmond, NL

T +31 (0)492 578 989

www.spirotech.co.uk

www.spirotech.com