

SPIROTECH SPECIFICATION SHEET



Product: SpiroCombi Rp^{3/4}" Universal Threaded fitting

Type:

UC075WJ

Date:

2/1/2024

Customer:

Project:

Reference:

Design criteria

Medium:	Water / glycol (max 50%)	
Max. flow velocity:	1	m/s
Max. flow rate:	1.30	m ³ /h
Max. pressure:	10	bar-g
Max. temperature:	110	°C
Design standard:	EN 13445	

Testing and quality assurance

Leakage test:	no
Test certificate:	no
Design and manufacturing acc. 2014/68/EU:	yes
Material certificates (structural parts):	no
Drawing:	no

Construction materials

Body:	Brass
Swivel:	Brass
Deaeration cap:	Brass
Valve sealing:	Viton
Float:	PP
Drain valve:	Brass
Spirotube Tube:	Copper
Spirotube Wire:	Copper
Spirotube Solder:	Tin(SnCu3)
Magnet:	Neodymium

Drawing

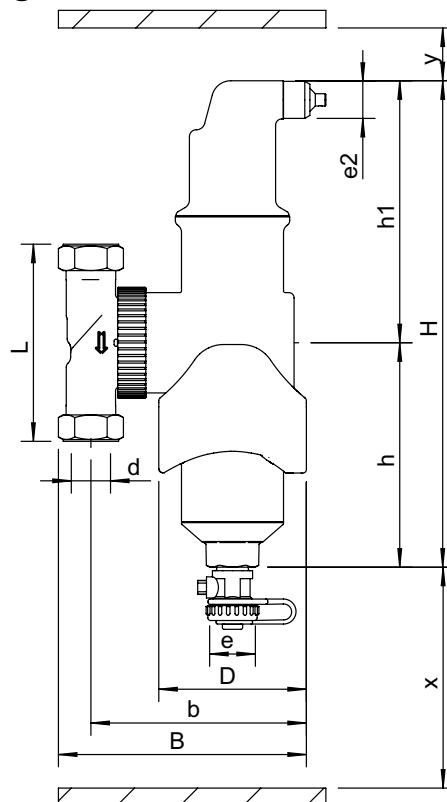

Dimensions

d:	Rp ^{3/4} "
H:	277 mm
h:	128 mm
h1:	149 mm
L:	92 mm
D:	84 mm
B:	142 mm
b:	125 mm
x:	>110 mm
y:	>75 mm
e:	G3/4
e2:	R1/2

Volume 0.58 ltr

Dry weight (approx) 2.4 kg

Subject to changes