

SPIRO  **TECH**
FOR BETTER PERFORMANCE

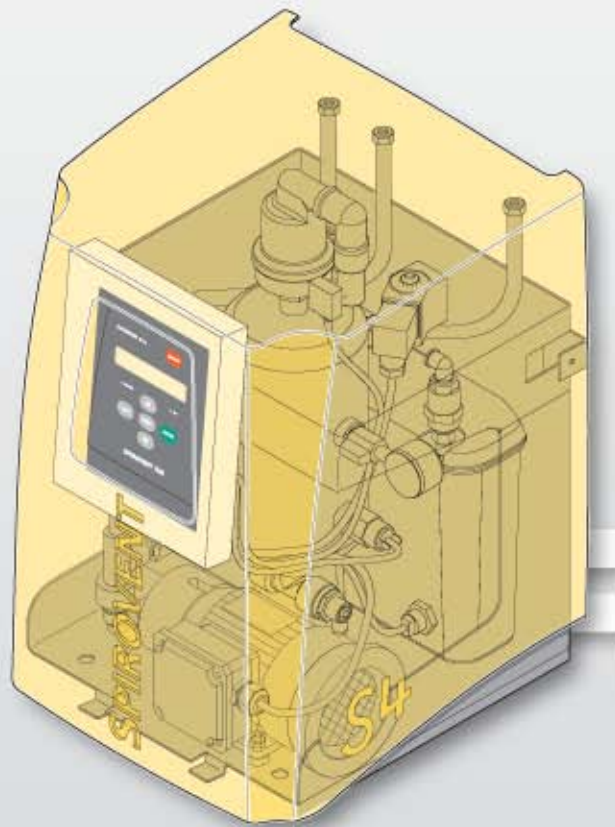

SPIROVENT SUPERIOR S4

TABLE OF CONTENT

1	<i>Preface</i>	3
2	<i>Introduction</i>	4
3	<i>Technical specifications</i>	6
4	<i>Safety</i>	8
5	<i>Installation and commissioning</i>	8
6	<i>Use</i>	13
7	<i>Failures</i>	14
8	<i>Maintenance</i>	17
9	<i>Guarantee</i>	19
10	<i>CE statement</i>	19

1 PREFACE

All rights reserved. No part of this manual may be duplicated and/or made public through the Internet, by means of printing, photocopying, microfilm or in any other way without prior written permission from Spirotech bv.





This manual has been composed with the utmost care. Should, however, this manual contain any inaccuracies, Spirotech bv cannot be held responsible for this.

This user manual deals with the installation, commissioning and operation of the SpiroVent Superior types S4A and S4A-R.

Always carefully read the instructions before installation, commissioning and operation. Keep the instructions for future reference.

1.1 Symbols

Throughout the instructions the following symbols are used:

	Warning or important note
	Advice
	Risk of electric shock
	Risk of burning

2 INTRODUCTION

2.1 Overview of the unit

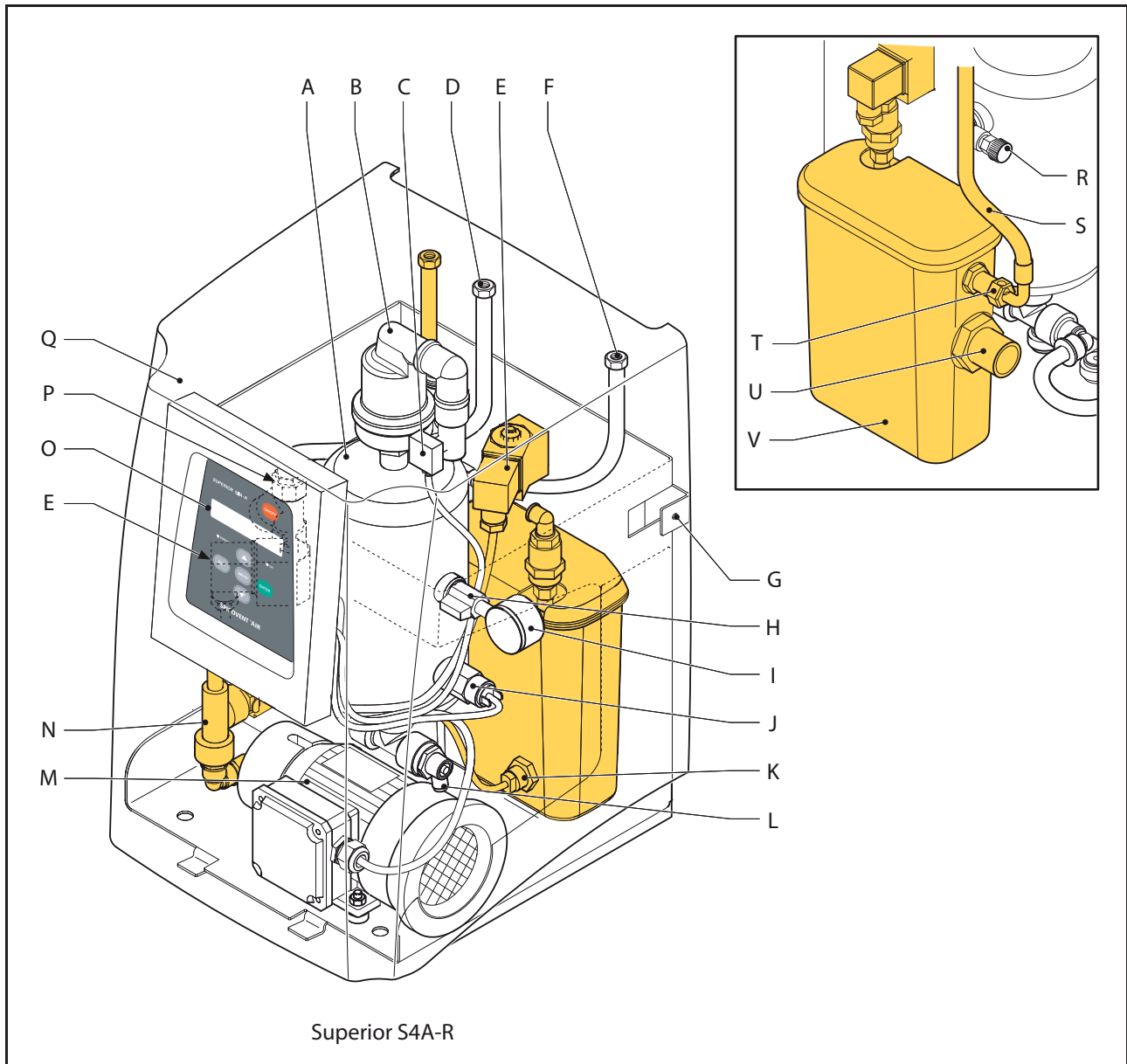

- | | | | |
|---|------------------------------|---|--------------------------------|
| A | Deaeration vessel | O | Control unit |
| B | Automatic air vent | P | Filter |
| C | SmartSwitch | Q | Cover |
| D | Outlet line | R | Aeration nipple |
| E | Solenoid valve | S | Refill connection (type S4A-R) |
| F | Inlet line | T | Float valve (type S4A-R) |
| G | Screws | U | Overflow (type S4A-R) |
| H | Valve behind pressure gauge | V | Refill reservoir (type S4A-R) |
| I | Pressure gauge | | |
| J | Pressure switch | | |
| K | Float switch (type S4A-R) | | |
| L | Drain connection | | |
| M | Pump | | |
| N | Pressure sensor (type S4A-R) | | |

2.2 Operation

The figure below schematically shows the operation of the unit. The letter indications comply with the main figure on the previous page.

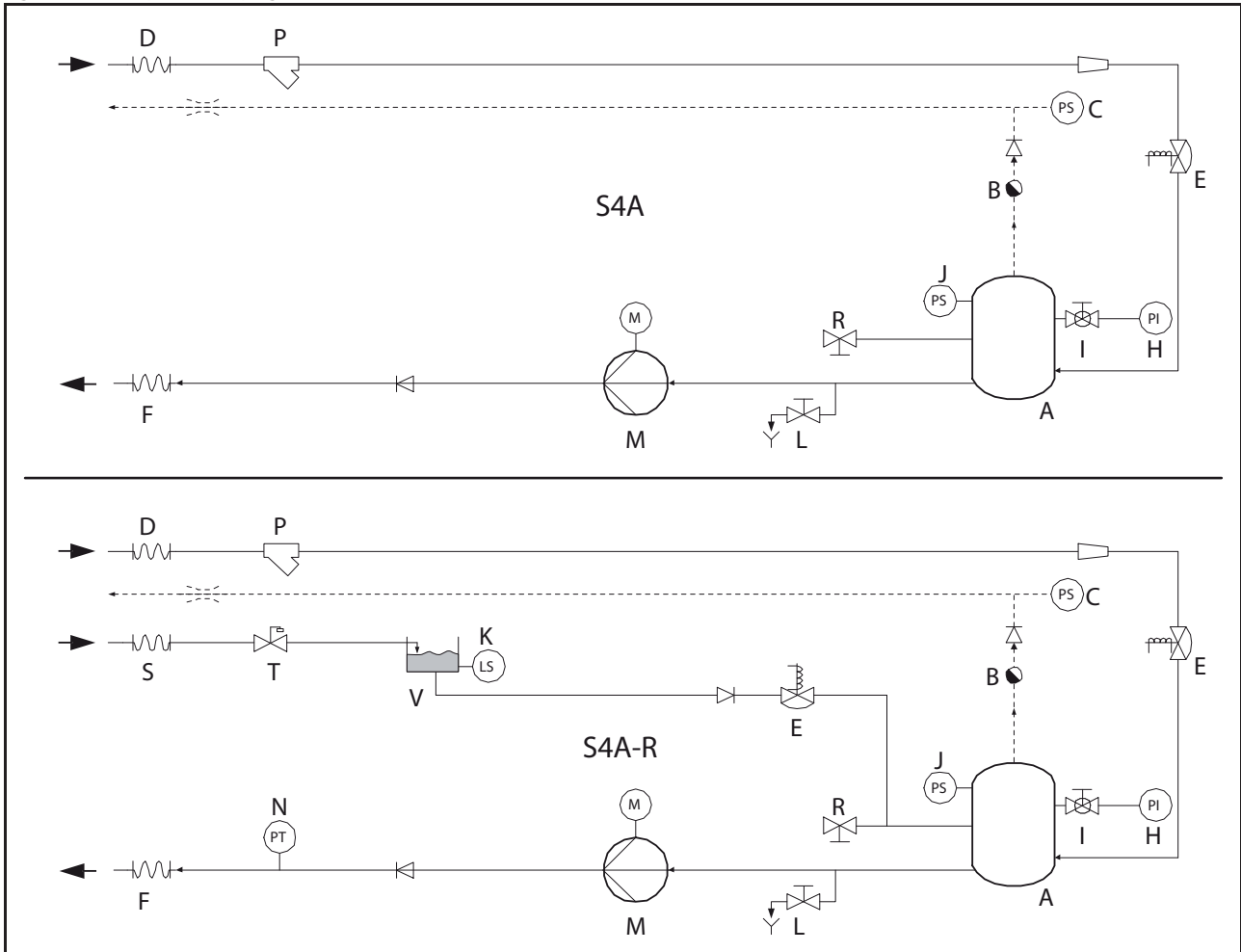

2.2.1 General

The Superior is a fully automatic vacuum degasser for installations filled with fluid. The fluid contains dissolved and undissolved gases. The function of the unit is to remove these gases from the installation until the concentration of undissolved gases has reached an absolute minimum. Problems caused by gases in the installation are thus eliminated.

Type S4A-R has an integrated refill automat. The refill automat maintains continuous pressure in the installation. For this the unit adds degassed fluid, if necessary.

2.2.2 Degassing

The unit starts up daily with the degassing process at a time indicated by the user. The process knows two phases:

- 1 The rinsing phase: The fluid flows from the installation through the solenoid valve (E) into the vessel (A). The pump (M) continuously pumps the

(degassed) fluid from the vessel into the installation. Here the degassed fluid absorbs gases again.

- 2 The vacuum phase: The solenoid valve (E) regularly closes, starting the vacuum phase. The continuously running pump (M) provides underpressure in the vessel (A). The underpressure causes the release of the gases dissolved in the fluid, which are collected at the top of the vessel. The solenoid valve (E) opens again, starting a new rinsing phase. The gases collected in the vessel are removed from the installation through the automatic air vent (B). The SmartSwitch (C) ensures that degassing is stopped as soon as the amount of dissolved gases has reached the minimum level.

2.2.3 (Re)fill

Type S4A-R continuously checks the system pressure. The refill process starts and stops automatically at the set values. Filling of the system can also be started by an external signal overruling the internal control of refilling.

2.3 Operating conditions

The unit is suitable for use in systems filled with clean water or mixtures of water with a maximum of 50% glycol. Use in combination with other fluids may result in irreparable damage.

The unit should be used within the limits of the technical specifications as given in chapter 3.



WARNING

- In case of doubt, always contact the supplier.
- In case of a contaminated system fluid, a dirt separator is to be installed in the main return line of the installation.

2.4 Scope of delivery

- 1x SpiroVent Superior
- 1x User manual

3 TECHNICAL SPECIFICATIONS

3.1 Dimensions

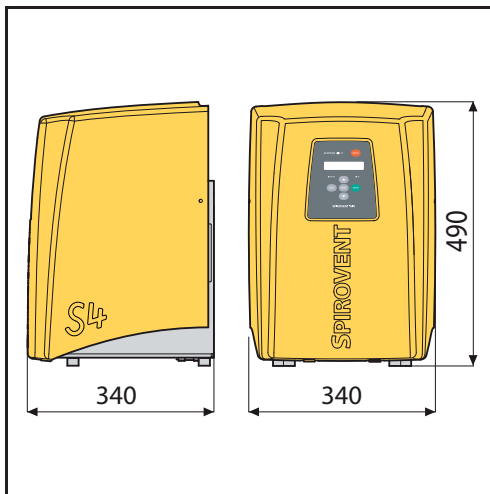

Height [mm]	Width [mm]	Depth [mm]
490	340	340

3.2 General specifications

	S4A	S4A-R
Max. system volume	25 m ³	25 m ³
Empty weight	15 kg	16 kg
Volume of degassing vessel	2 l	2 l
Inlet connection	Swivel G ¹ / ₂ " Bi	Swivel G ¹ / ₂ " Bi
Outlet connection	Swivel G ¹ / ₂ " Bi	Swivel G ¹ / ₂ " Bi
Noise level	52 dB(A)	52 dB(A)
Refill connection	n/a	Swivel G ³ / ₄ " Inside
Overflow connection	n/a	G1" Bu

3.3 Electrical specifications

	S4A	S4A-R
Supply voltage ¹⁾	230 V ± 10% / 50 Hz	230 V ± 10% / 50 Hz
Absorbed power	100 W	100 W
Nominal power consumption	0.5 A	0.5 A
Protection	3.15 A(T)	3.15 A(T)
Protection class	IP X4D	IP X4D
Max. load of potential-free contact (unit failure)	24 V / 1 A	24 V / 1 A
External refill signal (supplied voltage)	n/a	5 Vdc

1) 60 Hz on request

3.4 Other specifications

	S4A	S4A-R
System pressure ¹⁾	1 - 4.5 bar	1 - 4.5 bar
Ambient temperature	0 - 40 °C	0 - 40 °C
Maximum pressure	10 bar	10 bar
(with closed valve behind pressure gauge)		
Refill flow	n/a	50 l/hr
System fluid temperature	0 - 90 °C.	0 - 90 °C
Refill pressure	n/a	min. 0.5 bar
Refill fluid temperature	n/a	0 -30 °C

1) 1.5 - 4.5 bar at 60 Hz

3.5 Building Management System (BMS)

The unit has been provided with one auxiliary contact for communication with a BMS.

Signal	S4A	S4A-R
Unit failure	Potential-free	Potential-free

3.6 External refill control

If an external device controls the refill, feed in a cable and connect this to connector J8. The control will sense an external (potential free) contact as signal to start filling until the contact is released again. This can also be regulated indirectly with BMS.

4 SAFETY

WARNING



- Installation and maintenance of the unit should only be carried out by qualified personnel.
- Remove the voltage and pressure from the unit before starting the activities.

WARNING



There are hot parts below the cover. Let the unit cool down before starting the activities.

4.1 CE marking

The unit has a CE marking. This means that the unit has been designed, constructed and tested in compliance with the current safety and health regulations. Provided that the user manual is adhered to, the unit can be safely used and maintained.

4.2 Type plate

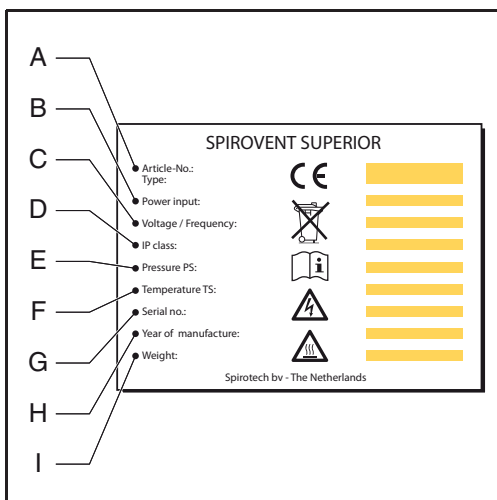

- A Article number
- B Type of the unit
- C Absorbed power
- D Supply voltage
- E Protection class
- F System pressure

- F System temperature
- G Serial number
- H Year of construction
- I Weight

The type plate has been applied on the inside of the unit. Remove the cover to read the data on the type plate.

5 INSTALLATION AND COMMISSIONING

5.1 Installation conditions

- Install the unit on a frost-free, well-ventilated place.
- Electrically connect the unit to a 230 V / 50 -60 Hz socket.
- Make sure the expansion system has the proper dimensions. The water displacement in the unit can cause pressure variations in the installation.

5.2 Unpack



WARNING

Do not hoist this equipment after the packaging has been removed. The use of hoisting belts, chains and hooks may cause irreparable damage.

The unit is supplied in a box.

1. Remove the packaging.

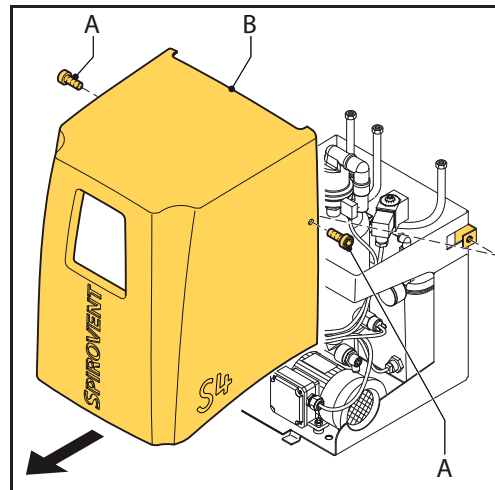

2. Loosen the screws (A).
3. Remove the cover (B) from the unit.
4. Move the unit to the place where it is to be installed.

5.3 Installation and mounting

CAUTION



- Install the unit in accordance with the local guidelines and rules.
- Install the unit as bypass on the main transport line of the installation.



NOTE

- Preferably install the unit at the point in the installation with the lowest temperature. Here the most dissolved gases are found in the fluid.
- Make sure when installing that the operating panel is always easily accessible.
- Make sure that you maintain a minimal distance for service and repair as indicated in the drawing below.

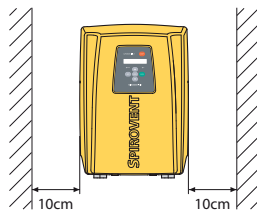

- The area at the right of the unit at the location of the "hole" S4" must be kept free and uncovered at all times for means of ventilation.

5.3.1 Mounting

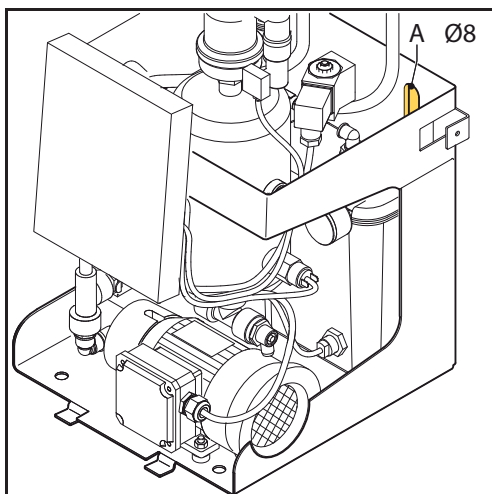

- **Wall mounting:** Mount the unit to a flat, closed wall using the holes (A). Make sure that the mounting can carry the filled unit (empty weight +2 kg).
- **Floor mounting:** Place the unit on a flat surface, against a flat, closed wall.

5.3.2 Installation

Mechanical

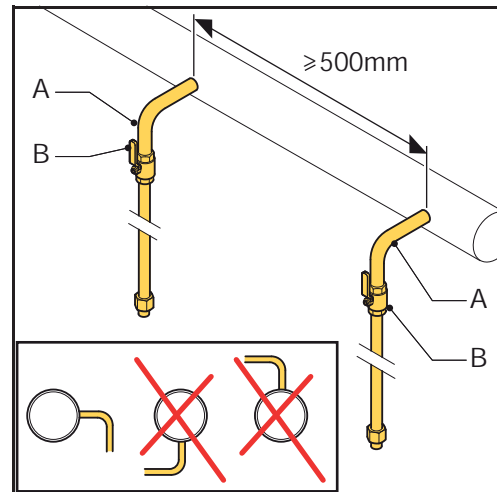

1. Make two branch lines 1/2" (A) on the side of the main transport line. The distance between them should be at least 500 mm.
2. Insert a valve (B) in each branch. With this the unit can be depressurised.



CAUTION

Make sure that the valves are opened before putting the unit into operation.

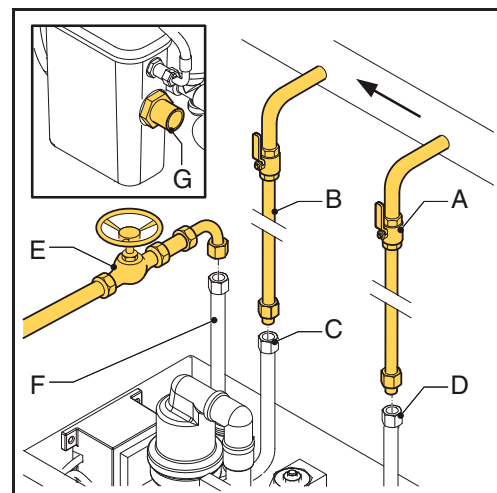

NOTE

As seen from the direction of the volume flow, the first branch is the inlet into the unit.

3. Connect the line (B) to the flexible outlet line (C).
4. Connect the line (A) to the flexible inlet line (D).

For type S4A-R:

1. Insert a cut-off valve (E) in the supply line of the refill fluid.
2. Connect the supply line to the refill connection (F) of the unit.
3. Connect the overflow (G) to a drainpipe connected to the sewage system.



CAUTION

Make sure that the lines leave the unit at the rear.

Electrical



CAUTION

- Preferably use a wall socket for the power supply to the unit. This should always be accessible.
- Mount an all-pole main switch (contact opening $\geq 3\text{mm}$) if the unit is directly connected to the power supply.
- Use supply cables with the correct dimensions.
- Always replace a defect fuse by a fuse of the same value. See § 3.3.

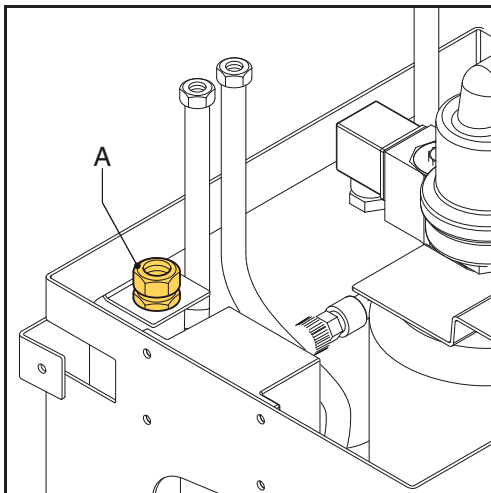

1. Feed a 3-core supply cable through swivel (A) and connect this to connector J10.

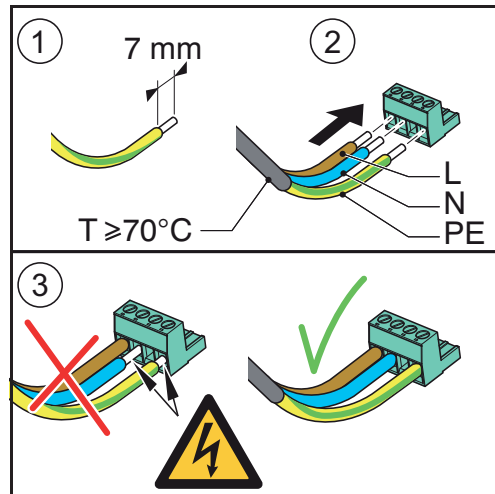

2. Insert the wires as indicated in the connector.

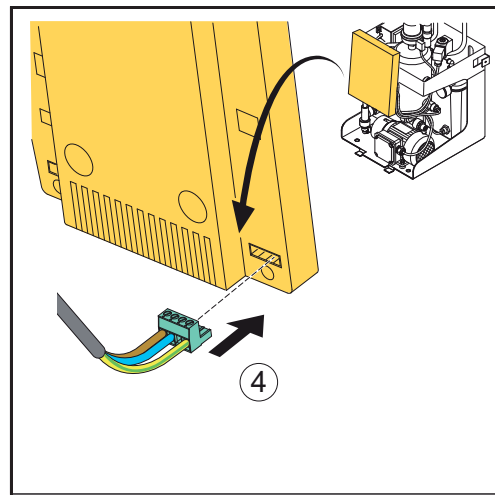

3. Insert the connector.

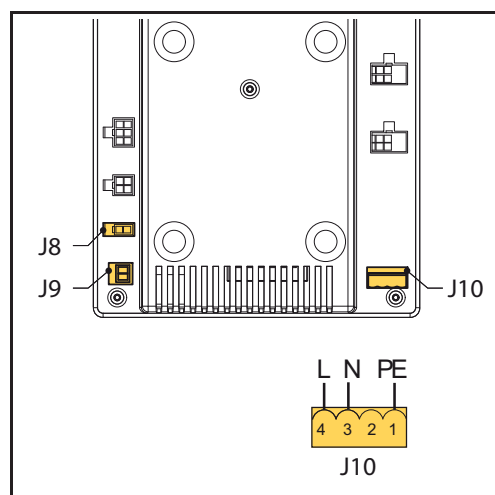

connector	contact	connection
J9	1 and 2	Failure
J8	1 and 2	External refill

- If a BMS is used, connect a BMS cable to connector J8 and/or J9.

Follow the procedures given below for entering the required parameters.

5.4 Commissioning

5.4.1 Preparation

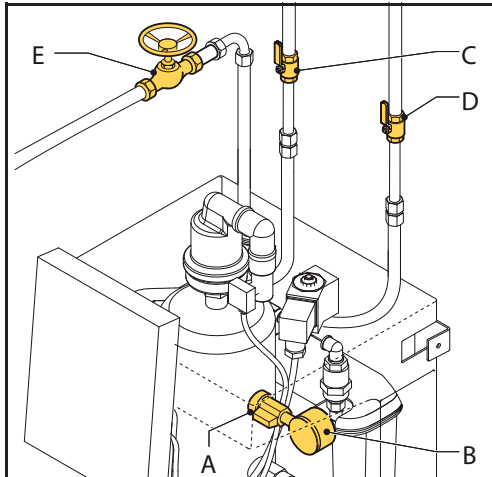

- Open valve (A) behind the pressure gauge (B)
- Open the valves (C and D) in the inlet and outlet lines.
- Open the valve (E) in the refill line.

5.4.2 Start up

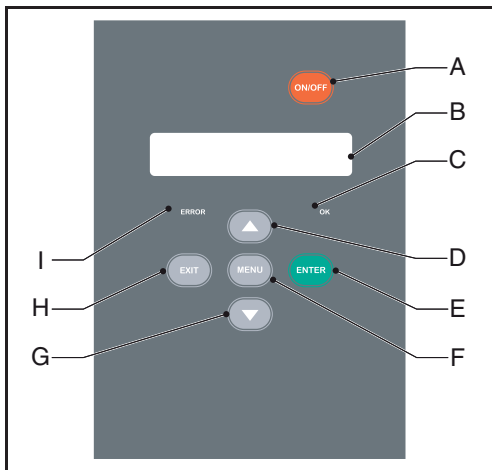

- A On/off
- B Display
- C Status report in operation / OK
- D Up
- E Confirm / Enter
- F Menu
- G Down
- H Cancel / Exit
- I Status report failure

CAUTION



- The start-up routine starts automatically when the unit is switched on for the first time.
- Press EXIT to go back one step in the menu while programming.

Set date en time

- Press ON/OFF.
- Select a language using ▲ and ▼. Press ENTER.
- Set the date using ▲ and ▼. Press ENTER.
- Set the day using ▲ and ▼. Press ENTER.
- Set the time using ▲ and ▼. Press ENTER.

Filling the unit

- Press ENTER. The unit starts filling.
- Wait for 50 seconds until Initial filling in process disappears.
- Press EXIT two times.



NOTE

The green LED "OK" indicates that the unit is ready for use. The degassing starts by default daily at 08:00 hours.

Check function

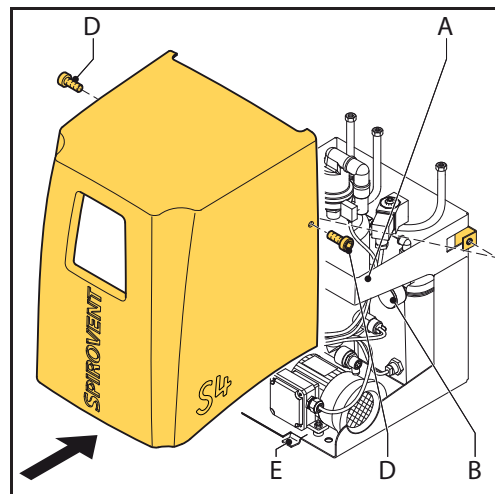

- Manually start the unit, see § 5.4.2.
- Check the indication of the pressure gauge (B). This should alternately display overpressure and underpressure.
- Close the valve (A) behind the pressure gauge.
- Place cover (C) back onto the unit. Slide the bottom of the cover in the recess (E).

5. Fasten the cover with the screws (D).



NOTE

The SmartSwitch will automatically turn off the unit when the concentration of dissolved gases has reached the minimum level.

5.5 Install and operate

5.5.1 Install

Set the user parameters

1. Press MENU. Select `Settings` using ▲ and ▼. Press ENTER.
2. Select the parameter to be changed using ▲ and ▼. Press ENTER.
3. Change the setting using ▲ and ▼. Press ENTER.
4. Repeat steps 2 and 3, if necessary.
5. Repeatedly press EXIT to return to the status report.

Parameter	Description
Language	Language for the display texts.
Date	The current date.
Weekday	The current weekday.
Time	The current time.
Auto start	Time for starting the degassing process.
Block.time, day	Time for stopping the degassing process.
Block.time week	Days of the week on which the unit is not working. Selected days are marked with an *. After having changed this parameter, select <code>Store</code> using ▲ or ▼. Press ENTER.
Block.time year 1	Period per year during which the unit is not working.
Block.time year 2 - 3	See Block.time year 1.
Max. Psystem *)	Pressure at which the unit stops.
Psystem desired*)	Pressure at which the refilling stops. Set this as low as possible if the refilling is controlled by the BMS or external devices (J8).
Refill on at*)	Pressure at which the refilling starts. Set this point as low as possible when the refilling is controlled by BMS or external devices.

Parameter	Description
Refill alarm after*)	Continuous refilling time (0 - 255 min.; 0 = switched off).
Max. refill freq. *)	Maximum number of times per day that refilling is allowed (0 - 10 times; 0 = switched off).

*) Applies to type S4A-R

5.5.2 Manual operation



NOTE

If manually switched off, the process must be manually switched on again.

1. Press MENU. Select `User menu > Manual operation` using ▲ and ▼. Press ENTER.
2. Select `Manual operation start` or `Manual operation stop` using ▲ and ▼. Press ENTER.

5.5.3 Switch on again

Follow the procedure described below after the unit has been switched off.

1. Press ON/OFF.
2. Press ENTER two times. The unit starts filling.
3. Wait for 50 seconds until `Initial filling in process` disappears.
4. Press EXIT two times.



NOTE

The green LED "OK" indicates that the unit is ready for use.

5.5.4 Reading the memory

During operation the following data are stored in the memory:

- Accumulative running hours
- Degassing history
- Fault history
- Refill history (only on type S4A-R).

The memory can be read in the following way:

1. Press MENU. Select `User menu > History` using ▲ and ▼. Press ENTER.
2. Select `Fault history` or `Action history` using ▲ and ▼. Press ENTER.
3. Select an item using ▲ and ▼. Press ENTER.
4. Repeatedly press EXIT to return to the status report.

5.5.5 Reading data

The following general data have been stored in the memory of the unit:

- Unit type
- Software version
- Installation date.

The general data can be read in the following way:

1. Press MENU. Select User menu > General data using ▲ and ▼. Press ENTER.
2. Select an item using ▲ and ▼. Press ENTER.
3. Repeatedly press EXIT to return to the status report.

6 USE

6.1 General

- The display lighting automatically dims after no key has been pressed for 5 minutes. Press a key to activate the lighting.

- While stopping the process a stop procedure is started, making sure that the unit stops in a safe situation (overpressure).
- When the pump has not run for 96 hours, an automatic pump test is run at the first next Auto start.
- Press ON/OFF to switch off the unit. Press ON/OFF again to switch on the unit again.
- At low fluid temperatures condensation may occur at certain parts. The condensation is drained through the openings in the frame.
- For type S4A-R:
The refill flow is about 50 litres per hour.

6.2 Status reports

Report	Description	LED indication
Auto pump test	The unit runs a pump test.	Green
End of degassing	The stop procedure is in process.	Green
End of refilling		
Degassing	The degassing process is in process.	Green
Process stopped	The unit has been stopped manually.	None
Standby	The unit is waiting for a starting signal.	Green
Failure	The unit has stopped because of a failure. Remedy the failure before resetting the unit, see § 7.4.	Red
Refill (only on S4A-R)	The unit is refilling fluid.	Green

7 FAILURES

7.1 Remedy failures

WARNING



- In case of failure always warn the installer.
- Remove the voltage and pressure from the unit before starting the activities see § 7.2.
- Pressing ON/OFF does **not** remove the voltage from the unit.

WARNING



There are hot parts below the cover. Let the unit cool down before starting the activities.

NOTE



In case of a failure the red LED is lit. The failure report appears in the display.

1. Localise the failure using the failure table, see § 7.3.
2. If necessary, put the unit out of operation, see § 7.2.
3. Remedy the failure.
4. Reset the unit, see § 7.4 or put the unit into operation again, see § 5.5.3.

7.2 Putting out of operation

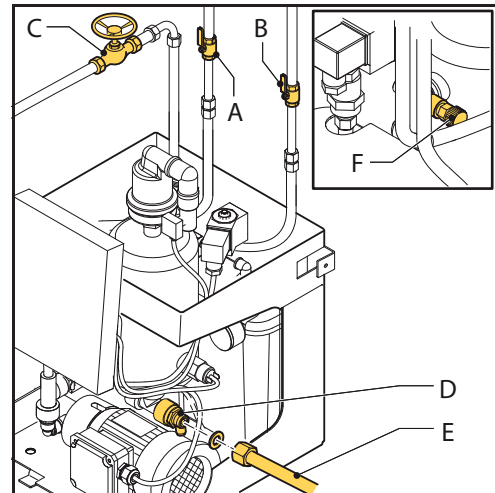

1. Take the plug out of the wall socket and switch off the main switch. Make sure that switching on the voltage unintentionally is not possible.
2. Close the valves (B) in the inlet pipe and (A) in the outlet pipe.
3. Close, if applicable, the valve (C) in the refill supply line as well.
4. Connect a drain line (E) to the drain connection (D).
5. Open the drain connection (D).
6. Open the aeration nipple (F)
7. Drain the unit through the drain connection (D).

7.3 Failure table

The letter indications comply with the main figure in § 2.1. An overview of the replacement parts has been included in § 8.2.

General

Problem	Possible cause	Correction
Err 5 Inlet flow The flow in the inlet line has been blocked.	The solenoid valve (E) in the inlet line does not open.	Replace (a part of) the solenoid valve.
	A valve in the inlet line is closed.	Open the valve.
	The filter (P) is clogged.	Clean the filter.
	The pressure switch (J) is defect.	Replace the pressure switch.
Err 6 Flow The flow in the outlet line has been blocked .	The solenoid valve (E) does not close (inlet pipe).	Replace (a part of) the solenoid valve.
	The valve in the outlet line is closed.	Open the valve.
	The outlet line has been obstructed.	Remove the obstruction.
	The pump (M) does not run.	Check the pump.
	The unit sucks in air during the vacuum phase.	Replace the automatic air vent.
	The pressure switch (J) is defect.	Replace the pressure switch.
The unit runs continuously and does not switch off automatically. The SmartSwitch does not seem to work.	The content of dissolved gases has not reached the minimum yet.	Check whether there is a possibility of gases entering the installation.
	The SmartSwitch (C) is defect.	Replace the SmartSwitch.
The unit runs maximally 10 min. per degassing period. Gases remain in the installation. The SmartSwitch does not seem to work.	The SmartSwitch (C) is defect.	Check whether gas is released through the valve. Replace the SmartSwitch if the valve does not work.
	The automatic air vent (B) is defect.	Replace the automatic air vent.

Applies specially to type S4A-R

Problem	Possible cause	Correction
Err 1 Psystem too low The system pressure is below 1 bar.	A failure in the installation.	Provide a system pressure of > 1 bar.
	There is a leak in the installation.	Repair the leak.
	The pressure sensor (N) is defect.	Replace the pressure sensor.
Err 2 Psystem too high The system pressure exceeds the set maximum.	A failure in the installation.	Provide a system pressure that is below the set value.
	The set value is too low.	Increase the set value.
	The pressure sensor (N) is defect.	Replace the pressure sensor.
Err 10 Refill flow too low There is no or little supply of refill fluid ¹⁾ .	A valve in the refill line is (partly) closed.	Open the valve.
	The refill line has been obstructed.	Remove the obstruction.
	The float switch (K) is defective.	Replace the float switch.
	The float valve (T) is defective	Replace the float valve
Err 13 Refill freq. too high Refilling takes place too frequently.	There is a leak in the installation.	Repair the leak.
		Check the setting Max. refill freq.
Err 14 Refill too long Refilling takes too long.	There is a leak in the installation.	Repair the leak.
		Check the setting Alarm refill after:

1) The refilling function remains active (type S4A-R only).

7.4 Resetting the unit

1. Press MENU. Select User menu > Manual operation using ▲ and ▼. Press ENTER.
2. Select Manual operation reset using ▲ and ▼. Press ENTER.

8 MAINTENANCE

8.1 Periodic maintenance

1. Inspect and clean the filter (P) regularly.
2. Replace the automatic air vent (B) every two years.

8.2 Replacement parts

The letter indications comply with the main figure in § 2.1.

Article number	Letter	Description
R16.181	M	Pump type MK309XE 50 Hz
R18.781	M	Pump type MK309XE 60 Hz
R18.782	M	Capacitor 50/60Hz
R18.748	Q	Cover
16.342	E	Solenoid valve (excluding coil)
16.343	E	Coil for solenoid valve
16.344	I	Pressure gauge
16.345	B	Automatic air vent
16.346	J	Pressure switch
R18.704	O	Control unit (S4A)
R18.705	O	Control unit (S4A-R)
16.349	C	SmartSwitch
R18.703	N	Pressure sensor (S4A-R)
16.355	P	Filter interior
16.351	T	Float valve
R18.904	K	Float switch

8.3 Maintenance card

Type: _____

Serial number: _____

Installation date: _____

Installed by firm: _____

Installed by technician: _____

Inspection date:	Technician:	Initials:
Nature of the maintenance:		

Inspection date:	Technician:	Initials:
Nature of the maintenance:		

Inspection date:	Technician:	Initials:
Nature of the maintenance:		

Inspection date:	Technician:	Initials:
Nature of the maintenance:		

Inspection date:	Technician:	Initials:
Nature of the maintenance:		

Inspection date:	Technician:	Initials:
Nature of the maintenance:		

9 GUARANTEE

9.1 Terms of guarantee

- The guarantee for Spirotech products is valid until 2 years following the purchasing date.

- The guarantee lapses in cases of faulty installation, incompetent use and/or non-authorized personnel trying to make repairs.
- **Consequential damage** is not covered by the guarantee.

10 CE STATEMENT

10.1 Declaration of conformity

According to EN-ISO/IEC 17050:2004

Manufacturer :Spirotech bv

Address :Churchillaan 52
5705 BK Helmond
The Netherlands

Products :SpiroVent Superior S4A / S4A-R

We declare entirely on our own responsibility that these products comply with the following standards:

EN 12100-1, EN 12100-2, EN 809, EN 60204-1, EN60335-1,
EN 61000-3-2, EN 61000-3-3, EN 55014-1, EN 55014-2, EN 61000-6-1, EN 61000-6-2, EN 61000-6-3 and
EN 61000-6-4.

in accordance with the stipulations of:

- Machine Directive 2006/42/EC
- Low Voltage Directive 2006/95/EC
- EMC Directive 2004/108/EC

Helmond, validated 1 July 2010,



Dr. D. Scholten
Managing Director



The manufacturer reserves the right to make changes without prior notification.

© Copyright Spirotech bv

Information given in this brochure may not be reproduced complete or in part without the prior written consent of Spirotech bv.

Spirotech bv

The Netherlands

www.spirotech.com